

T.O. 31R2-3BC639-22
(Formerly 31R2-3SGR574-42)

HANDBOOK
MAINTENANCE INSTRUCTIONS

RADIO RECEIVER
BC-639-A

REVISION
NOTICE

LATEST REVISED PAGES SUPERSEDE
THE SAME PAGES OF PREVIOUS DATE

PUBLISHED UNDER AUTHORITY OF THE SECRETARY OF THE AIR FORCE
AND THE CHIEF OF THE BUREAU OF AERONAUTICS

SECTION I
GENERAL DESCRIPTION

1. GENERAL.

a. Radio Receiver BC-639-A is a superheterodyne receiver. It receives both radiophone communication and direction-finding signals from aircraft.

The entire receiver unit is mounted on a shelf type chassis and all of the components are supported from the front panel. The receiver is used for standard rack mounting in ground stations. The chassis has a dust proof cover which is held securely in place by fifteen binder-head screws.

Since the heat (power) given off by the receiver is small, ventilating louvers are left out, and the receiver is dust proof.

Radio Receiver BC-639-A receives amplitude modulated or c-w radio signals on the ultra-high frequency band from 100 to 156 megacycles (1.92 to 3 meters). Its slow-motion drive dial gives complete frequency coverage without switching.

The receiver consists of:

- (1) A radio frequency amplifier stage
- (2) An oscillator stage
- (3) A doubler stage
- (4) A mixer stage
- (5) Three intermediate frequency amplifier stages, using an intermediate frequency of 12 megacycles
- (6) A second detector stage
- (7) A first audio stage (combined in a single tube with the 2nd detector stage)
- (8) An audio output amplifier stage
- (9) A beat frequency oscillator which feeds into the second detector and can be switched into the circuit when needed.

The beat frequency oscillator is used for taking D/F bearings on an unmodulated carrier and for the reception of c-w telegraph signals. The receiver has good automatic volume control and good frequency stability. It will function for a long time without frequent monitoring. A manual volume control is used in taking bearings for D/F service.

The power supply is not built into the receiver but a cable which plugs into the rear of the chassis connects the receiver to the separate power supply.

The audio frequency response of Radio Receiver BC-639-A gives greatest clearness to speech signals. The response is practically flat from 600 to 3000 cycles, but it is 10 db down at 200 cycles. The frequencies above 3000 cycles, are also attenuated and the response is 10 db down at 5000 cycles.

The output of the receiver is connected to two terminals of socket 263 which is at the rear of the chassis. Socket 263 is a six-contact socket through which all outside connections are made to Radio Receiver BC-639-A, (except for the antenna) by means of a power supply cable and Jones plug connection. The output of the receiver feeds directly into a telephone line system, the output impedance having been chosen to satisfy this requirement. The output transformer has a balanced output and an electrostatic shield between the windings so the receiver output circuit is suitable for direct connection to the telephone line circuit. Provisions for Loudspeaker LS-3 operation is provided. Two telephone jacks are on the front panel; the one marked MONITOR, is used for monitoring the receiver at any time, the other, marked LINE, is wired so that when a plug is put into it, the output of the receiver is disconnected from socket 263 at the rear of the unit by opening both sides of the output circuit and will be heard only in the headset plugged into the LINE and MONITOR jack. The receiver works into a 600-ohm load, but good operation will be had when operating into any load between 200 and 20,000-ohms.

b. **FRONT PANEL.**—The front panel of Radio Receiver BC-639-A has the following controls, indicators and receptacles: (fig. 1)

(1) **TUNING CONTROL.**—The tuning control is a slow motion drive dial. It is on the left side of the panel. The control drives the five tuning capacitors for a complete coverage of the frequency band (100-156 megacycles). The dial is calibrated directly in megacycles and the scale moves behind a window just above the control knob. A dial light (6-8 volt, .25 ampere, bayonet base bulb, Mazda #44) indirectly lights the scale.

(2) **SENSITIVITY CONTROL.**—At the bottom of the panel and to the left of a row of three control knobs is a screw cap which covers the THRESHOLD SENSITIVITY control. This control

is a slotted shaft for screwdriver adjustment. It is covered by a screw cap which you must remove (by hand) before you can adjust it. This control is used to set the maximum gain of the receiver and when you have once set it at a particular place you should not change it.

(3) **R.F. GAIN INCREASE CONTROL.**—Next to the **THRESHOLD SENSITIVITY** control is the **R.F. GAIN INCREASE** control knob which controls the radio frequency sensitivity of the receiver. An arrow on the plate above this knob shows the direction to turn the control for an increase in r-f gain.

(4) **C.W. AND MANUAL, MANUAL, A.V.C. SWITCH.**—The third control is a three-position switch marked **C.W. AND MANUAL, MANUAL, A.V.C.**

(a) The **C.W. AND MANUAL** position is for receiving unmodulated signals with manual control of the volume;

(b) The **MANUAL** position is used for receiving modulated signals with manual control of the volume;

(c) The **A.V.C.** position is for receiving modulated signals with automatic volume control.

(5) **AUDIO GAIN INCREASE.**—The last control on the lower right hand side of the panel is the **AUDIO GAIN INCREASE** which controls the output volume. It has an arrow marking the direction of increase.

(6) **ATTENUATION SWITCH.**—At the center of the front panel and to the right of the tuning control, is a three-position switch marked **ATTENUATION**. This switch has three positions marked **-12 DB, -6 DB, 0 DB**. This switch gives different maximum power outputs.

(7) **C.W. TONE CONTROL.**—The second control knob is the **C.W. TONE CONTROL** which varies the beat note when receiving unmodulated signals.

(8) **MONITOR JACK AND LINE JACK.** The two output jacks are on the right side of the panel, and are marked **MONITOR** and **LINE**. Putting a headphone plug into the **MONITOR** jack will place the headphones across the line without interrupting the circuit. Inserting the headphone plug into the **LINE** jack places the headphones across the receiver output which is then disconnected from the line.

(9) **TUNING METER.**—The **TUNING METER** is at the top of the front panel. It shows the current drawn by the first intermediate frequency amplifier Tube VT-211. When the **C.W. AND MANUAL, MANUAL, A.V.C.** switch is at **A.V.C.**, it is used in tuning the receiver to exact resonance.

NOTE

All Radio Receivers BC-639-A, with serial numbers higher than No. 2595, have a dial lock and jack covers.

2. COMPONENTS

<i>Description</i>	<i>Overall size in inches (Including projections)</i>	<i>Weight in lbs.</i>	<i>Sig. C. Stock No.</i>
1 Radio Receiver BC-639-A (complete with tubes)	19 x 10 ¹⁵ / ₁₆ x 13 ⁹ / ₁₆	38	2C4439A
Radio Receiver BC-639-A uses either of following two power supplies:—			
1 Rectifier RA-42-A,	19 x 6 ³¹ / ₃₂ x 8 ²³ / ₃₂	26	3H4682A
Rectifier RA-42-B	19 x 6 ³¹ / ₃₂ x 8 ²³ / ₃₂	26	3H4682B
or			
1 Dynamotor Unit PE-100-A	19 x 10 ¹⁵ / ₁₆ x 8 ¹¹ / ₁₆	24	6D7800T100A
1 Case CS-134	10 x 10 ¹ / ₂ x 12	11	6D7400T639A
2 AN 08-10-216, Handbook of Maintenance Instructions for Radio Receiver BC- 639-A	8 ¹ / ₂ x 11		

Both power supplies are described in separate instruction books;

TUBE COMPLEMENT.

<i>Quantity</i>	<i>Mfr. Type</i>	<i>Name</i>	<i>Signal Corps Type</i>
1	6SQ7	Duplex-diode high-mu triode	VT-103
1	6K6-GT/G	Power amplifier pentode	VT-152
1	9002	Triode	VT-202
3	9003	Semi-remote cut-off pentode	VT-203
4	6SG7	Remote cut-off pentode	VT-211

3. ANTENNA REQUIREMENTS.

a. The antenna input to Radio Receiver BC-639-A works in conjunction with a 70-ohm coaxial cable which has the outside grounded; however, good results will be obtained with anything from 20 to 100 ohms. You will get the best results by using a $\frac{1}{2}$ wave dipole antenna placed as high as possible, and connected to the receiver by means of a 70-ohm coaxial transmission line. Connections are made to a special coaxial antenna socket at the rear of the receiver chassis.

4. POWER REQUIREMENTS.

a. The power input to the receiver from the power supply unit is as follows:

210 volts direct current, (180 volts minimum, 240 volts maximum). Current drain 60 milliamperes at 210 volts.

6.3 volts, 3.5 amperes, alternating current or direct current.

In an installation where both Rectifier RA-42-A, (or Rectifier RA-42-B) and Dynamotor Unit

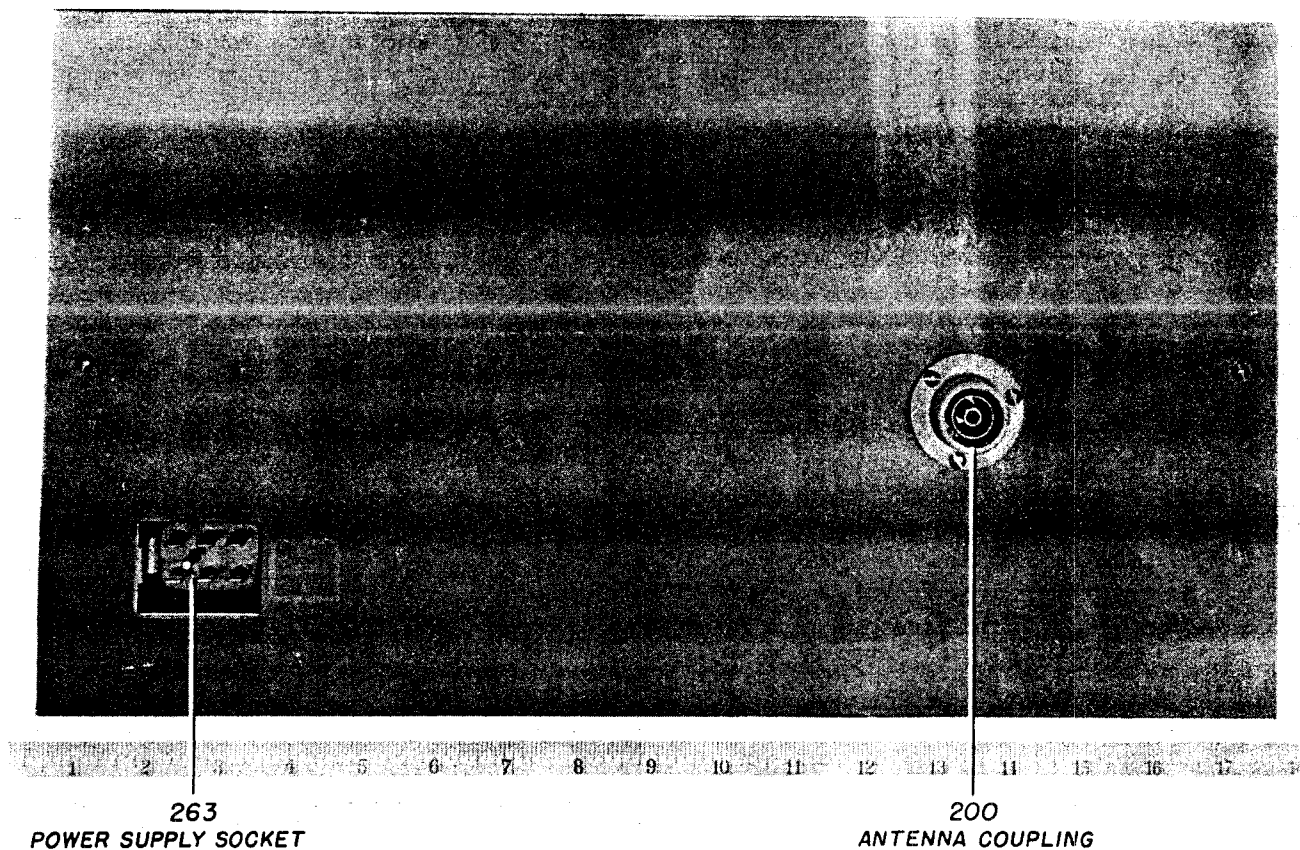

Figure 2 — Radio Receiver BC-639-A, Rear View, Dust Cover In Place

PE-100-A are used, the receiver is connected directly to a switch panel so you can switch to either power supply. In installations where only Rectifier RA-42-A (or Rectifier RA-42-B) is used, the receiver is connected directly to the power supply. If only the Dynamotor Unit PE-100-A is used, a separate single-pole, single-throw switch, is located externally to both the receiver and to Dynamotor Unit PE-100-A. It turns the dynamotor unit on and off.

5. TABLE MOUNTED IN CASE CS-134, NAVY ADAPTATION.

There are two models of Radio Receiver BC-639-A. One of these (Table Mounted, Navy Adaptation) is used only by the U. S. Navy while the other is supplied to the U. S. Army. These receivers are the same as the rack mounted Radio Receiver BC-639-A except for the following differences:

a. Radio Receiver BC-639-A (Table Mounted, Navy Adaptation) is mounted in Case CS-134 supported on four Lord shockmounts. This case replaces the dust cover used in the rack mounted radio receiver. The mounting screw passes through a washer and sleeve in the shockmount.

b. Case CS-134 is equipped with eight sets of contact springs. Four sets at the bottom front of the case and four sets at the top front of the case. These contact springs are used to make electrical connections between the front edge of the case and the front panel of the receiver thus making the shielding of the receiver complete.

c. The receiver is held in the case by six knurled thumbscrews which are located three on each side of the case. These screws are not removable; they are held in slots in the case by "C" washers.

d. The flange supporting the outside antenna coupling and the hole in the case through which the coupling fits, have been enlarged so that the outside antenna coupling does not need to be removed from the chassis when removing the receiver from the case.

(1) The model supplied to the U. S. Army uses three screws in the case around the outside antenna coupling to make a firm contact.

(2) The model supplied to the U. S. Navy uses no screws in the case around the outside antenna coupling but has four sets of four grounding springs around the outside antenna coupling hole inside the case for good contact when the receiver is placed in the case.

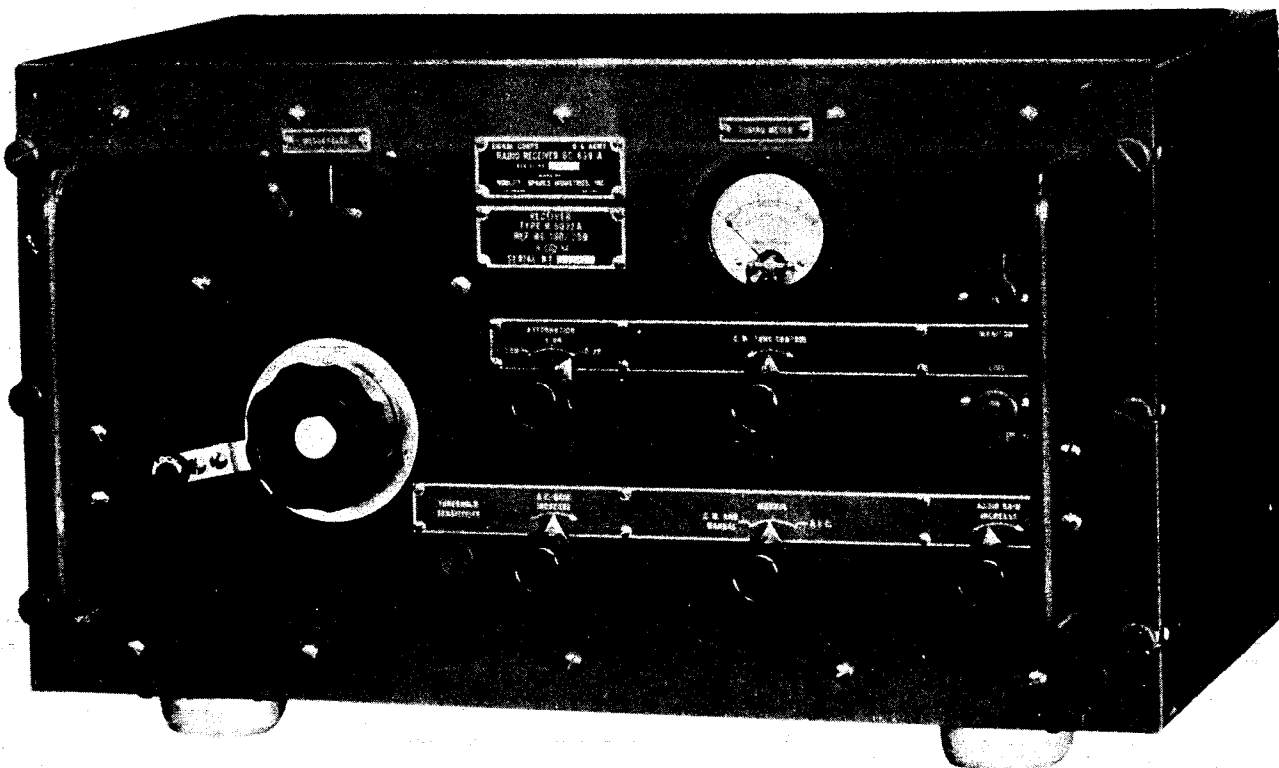

Figure 3 — Radio Receiver BC-639-A, (Navy Adaptation) Mounted in Case CS-134

SECTION II

INSTALLATION AND ADJUSTMENT

6. INSTALLATION.

a. **INSTALLATION STANDARD RACK MOUNTING.**—Grasp Radio Receiver BC-639-A by the handles mounted on the front panel (fig. 1) and slide it into its standard rack mounting from the front. The receiver is held in the rack by six #10-32 fillister-head screws, (with a lock washer and flat washer located under the head of each screw). Be sure that the flat washer is placed next to the panel. All outside connections to the receiver are made to the antenna socket 200 and to the power plug socket 263 at the rear of the chassis. When the unit is fastened firmly to the rack put the Jones plug, used for outside power and output connections, into the six-contact socket 263 provided for it in the rear of the chassis. (The six-contact socket is shown in figure 4.)

The receiver is connected to the dipole antenna through a 70-ohm coaxial antenna line. (20-100-ohms will give satisfactory results.) The coaxial cable used

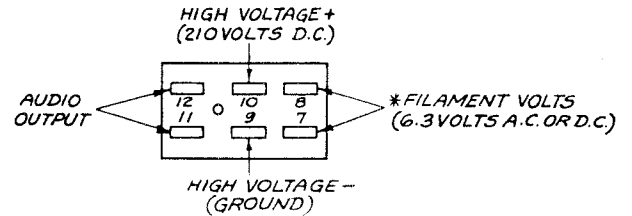

**IF DIRECT CURRENT IS USED FOR FILAMENT SUPPLY, TERMINAL 8 IS PLUS AND TERMINAL 7 IS MINUS. TERMINAL 7 IS GROUNDED INSIDE THE CHASSIS.*

A113255

**Figure 4 — Radio Receiver BC-639-A,
Socket Connections**

is complete with fittings for ease of assembly. It only needs to be plugged into the antenna socket 200 and locked in place with the lock nut on the end of the cable. (See figure 2 for position of antenna socket 200 and socket 263.)

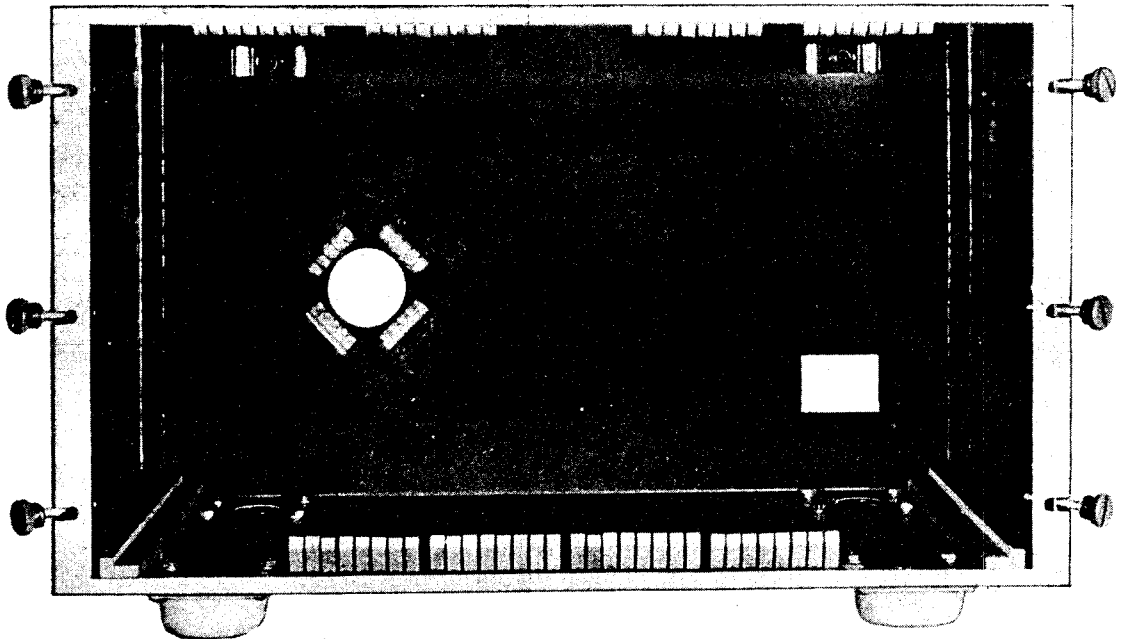

Figure 5 — Case CS-134

b. INSTALLATION IN CASE CS-134.

- (1) Grasp the handles located on the front panel.
- (2) Slide the unit into the case from the front. The brackets on the bottom of the unit fit into a grooved wooden track.
- (3) Slide the unit into the case as far as it will go. Tighten the six knurled screws which will push the receiver firmly against the contact springs and hold it there.

c. INTERCHANGEABILITY OF DUST COVER AND CASE CS-134.—The dust cover used on the rack mounted radio receiver may be used on any Radio Receiver BC-639-A in place of the Case CS-134 by removing the outside antenna coupling, placing the receiver in the dust cover, then replacing the outside antenna coupling and fastening the three screws which hold the coupling to the flange.

7. PREPARATION FOR USE.

The Radio Receiver BC-639-A comes equipped with tubes mounted in the set. Everything should

be complete and the receiver ready for operation. Prepare Radio Receiver BC-639-A for use as follows:

- a. Insert the power plug in the rear of the receiver.
- b. Connect the antenna plug to the antenna socket at the rear of the unit.
- c. Check the power input voltage and frequency to the power supply. This should be 90 to 140 volts or 200 to 250 volts, 60 cycles, alternating current for Rectifier RA-42-A (or Rectifier RA-42-B), or 6-volts direct current for Dynamotor Unit PE-100-A.
- d. Turn on the power on Rectifier RA-42-A (or Rectifier RA-42-B) by use of the POWER ON switch on the rectifier panel, or if the Dynamotor Unit PE-100-A is used, place switch at BATTERY or Switch Panel PN-6-A.
- e. If Rectifier RA-42-A is used, wait approximately 30 seconds; the voltmeter on the rectifier panel should then indicate about 60 MA.
- f. The receiver is now ready for operation.

SECTION III

OPERATION

8. GENERAL.

a. When power is supplied, dial lamp on the receiver should light.

b. Set the ATTENUATION switch to 0 DB.

c. Set the R.F. GAIN INCREASE control and AUDIO GAIN INCREASE control to maximum. (Turn knobs clockwise, to the right all the way).

d. Plug earphones in MONITOR jack on front panel of receiver.

e. With normal voltage applied and C.W. AND MANUAL, MANUAL, A.V.C. switch set at MANUAL, set the THRESHOLD SENSITIVITY for about 5 ma.

9. TUNING RECEIVER TO A DESIRED FREQUENCY WITH FREQUENCY METER BC-638-A.

a. If Frequency Meter BC-638-A is available, insert proper crystal (whose frequency is desired frequency \div 18) in Frequency Meter BC-638-A, set CRYSTAL SELECTOR switch to position corresponding to the number of the crystal selected, turn MIN.-MED.-MAX. switch to MAX., turn ON-OFF switch to ON, set STAND BY-OPERATE switch to OPERATE and turn tuning knob so that the green glow of the "magic-eye" indicator tube makes the smallest angle. The dial reading in megacycles should be about 18 times the crystal frequency. *For complete details see Handbook of Maintenance Instructions for Frequency Meter BC-638-A.*

b. Set C.W. AND MANUAL, MANUAL, A.V.C. switch on receiver to A.V.C.

c. The main tuning dial is directly calibrated in megacycles. Turn the tuning dial so that the dial reading is the same as the frequency desired. A 1000 cycle note should be heard in the earphones.

CAUTION

It occasionally happens that the dial calibration is off from 1 to 3 divisions. Therefore, if no signal is heard when the dial is set to the desired frequency, rotate the dial slowly about 3 or 4 divisions to each side of the desired dial reading and listen for the signal to come in.

d. Adjust the main tuning dial for the loudest signal which will be the same setting as the minimum reading on the TUNING METER.

e. The receiver is now tuned to the desired frequency. *Now be sure to turn the frequency meter to STAND BY.*

10. TUNING RECEIVER TO A DESIRED FREQUENCY WITHOUT USING FREQUENCY METER BC-638-A.

a. Set C.W. AND MANUAL, MANUAL, A.V.C. control to A.V.C.

b. The main tuning dial is directly calibrated in megacycles so that the dial can be tuned directly to the frequency desired. If a transmission on a known frequency is to be picked up, turn the tuning dial until it reads about the same as the transmission frequency. If the signal is strong enough to be heard turn the dial for the loudest signal which will be the same setting as for the minimum reading on the TUNING METER.

11. USE OF CONTROLS AFTER RECEIVER IS TUNED TO DESIRED FREQUENCY.

a. For amplitude-modulated communication, set the receiver controls as follows:

(1) Set the C.W. AND MANUAL, MANUAL, A.V.C. control at A.V.C.

(2) Set the ATTENUATION control at 0 DB.

(3) Set the AUDIO GAIN INCREASE control at a comfortable level after the signal has been tuned in.

(4) The R.F. GAIN INCREASE and the C.W. TONE CONTROL are not used for communication reception.

b. For c-w signals, set the receiver controls as follows:

(1) Set the C.W. AND MANUAL, MANUAL, A.V.C. control at C.W. AND MANUAL. The beat frequency oscillator now comes into operation.

(2) Set the AUDIO GAIN INCREASE control at maximum (fully clockwise).

(3) Set the ATTENUATION control at 0 DB.

(4) The receiver should be tuned to zero beat (no whistle), when the C.W. TONE CONTROL pointer is at the index line. If the receiver is not then tuned to zero beat, adjust the main tuning dial for zero beat with the C.W. TONE CONTROL pointer at the index line.

(5) Adjust the C.W. TONE CONTROL for the most pleasing tone.

(6) Set the R.F. GAIN INCREASE control to the point where the signal is just comfortably audible. *To avoid overloading and to give a sharp minimum, it is very important to work at a low signal level by reducing the setting of the R.F. GAIN INCREASE control as much as possible.*

(7) The C.W. TONE CONTROL may need readjustment to keep the note audible.

c. For direction finding on a modulated signal, set the receiver controls as follows:

(1) Set the C.W. AND MANUAL, MANUAL, A.V.C. control at MANUAL.

(2) Set the AUDIO GAIN INCREASE control at maximum (fully clockwise).

(3) Set the ATTENUATION control at 0 DB.

(4) Set the R.F. GAIN INCREASE control at the point where the signal is just comfortably audible. *To avoid overloading and to give a sharp minimum, it is very important to work at a low signal level by reducing the setting of the R.F. GAIN INCREASE control as much as possible.*

12. USE OF THE TUNING METER

In addition to the above use for tuning the receiver, the TUNING METER indicates the strength of the incoming signal. A strong signal produces a large reduction while a weak signal produces a small reduction in reading. The approximate values are as follows:

Signal Strength		Ma On TUNING METER
zero	microvolts	5.0 MA
10	microvolts	5.0 MA
100	microvolts	4.8 MA
1000	microvolts	3.2 MA
10,000	microvolts	2.0 MA
100,000	microvolts	1.2 MA

REMEMBER THESE POINTS

1. Make sure that the antenna plug is firmly seated in the antenna socket at the rear of the receiver.
2. If available always use the Frequency Meter BC-638-A for tuning the receiver to the desired frequency.
3. Make sure that the Frequency Meter BC-638-A has been switched to STAND-BY after it has been used to tune the receiver.
4. Since the calibration of the receiver may drift slightly for about the first twenty minutes, the receiver should be allowed to warm up at least twenty minutes before the final tuning is begun.
5. While monitoring, keep the receiver GAIN controls turned up. This way faint signals will not escape your attention.

SECTION IV MECHANICAL AND ELECTRICAL CHARACTERISTICS

13. GENERAL.

Radio Receiver BC-639-A consists of:

1. A radio frequency amplifier stage
2. An oscillator
3. An oscillator doubler
4. A mixer stage
5. Three intermediate frequency amplifier stages
6. A second detector
7. Automatic volume control
8. First audio stage
9. An audio output stage
10. A *beat frequency oscillator can be switched into the second detector when desired.*

The schematic diagram of Radio Receiver BC-639-A is shown in fig. 22. A block diagram of Radio Receiver BC-639-A is shown in fig. 6.

The antenna socket on the receiver unit is coupled to the grid coil of the radio frequency amplifier stage by a short piece of coaxial transmission line. The radio frequency stage uses a pentode Tube VT-203 (9003). From the radio frequency stage the signal frequency is fed into a mixer stage which uses the same type tube. The plate circuit of the mixer is tuned to the intermediate frequency of 12 megacycles. There are three intermediate frequency stages using remote cut-off pentode Tubes VT-211 (6SG7). From the third intermediate frequency stage the intermediate frequency of 12 megacycles is fed into diode plate #1 of the second detector and first audio amplifier stage, which uses a single Tube VT-103 (6SQ7). The detected signal is fed through the ATTENUATION switch into the grid of the second audio Tube VT-152 (6K6-GT G), which is the audio output stage.

The output frequency of the doubler Tube VT-203 (9003) differs from the signal frequency by

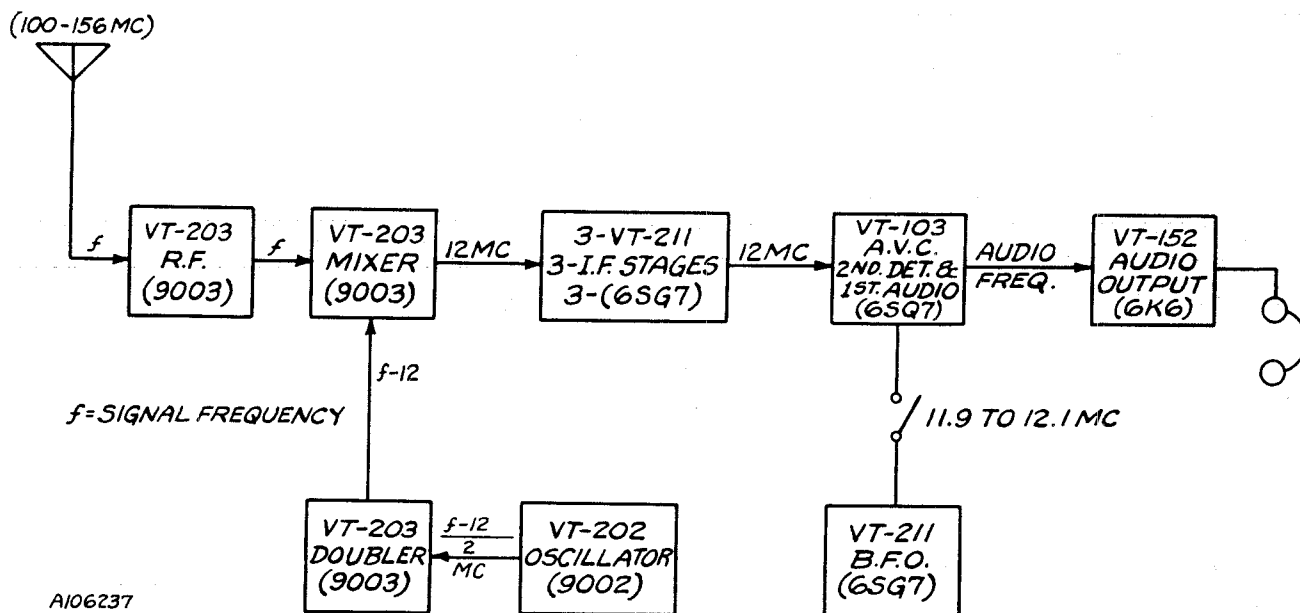

Figure 6 — Radio Receiver BC-639-A, Block Diagram

12 megacycles and the high frequency oscillator Tube VT-202 (9002), is tuned to half the doubler output frequency. Thus while the signal frequency circuits tune from 100 to 156 megacycles, the doubler tunes from 88 to 144 megacycles, and the high frequency oscillator tunes from 44 to 72 megacycles. The local signal from the doubler and high frequency oscillator is introduced into the mixer by inductive coupling between the mixer grid coil and the doubler plate coil.

The output of the beat frequency oscillator, which uses a remote cut-off Tube VT-211 (6SG7), is injected into diode plate #1 of the second detector which is used for demodulation. The beat frequency oscillator is automatically turned on when the C.W. AND MANUAL, MANUAL, A.V.C. switch is set at C.W. AND MANUAL.

The filaments of all of the tubes in the receiver unit operate from a 6 volt supply.

The plate voltage supply should be 210 volts, D. C.

14. CIRCUITS OF THE RADIO FREQUENCY AMPLIFIER.

When a VHF signal is introduced into the antenna coil 201 it causes a radio frequency voltage to appear across the upper portion of the coil due to autotransformer action. This voltage is applied to the control grid of the radio frequency amplifier Tube VT-203 (9003), through the 15-mmf coupling capacitor 203. One stage of amplification at signal frequency is provided using a VT-203 (commercial type 9003) super-control pentode tube, in a tuned-grid, tuned-plate amplifier circuit, with coil 201, and variable capacitors 202A and 204-1 tuning the grid circuit, and with coil 212, and variable capacitors 202B and 204-2 tuning the plate circuit. Variable capacitors 202A, 202B and 202C form a three-gang tuning capacitor with an ungrounded rotor.

Concentric type trimmer capacitors 204-1, 204-2, and 204-3 are connected across the three sections of this capacitor. Alignment at the factory is done by bending the coils 201 and 212, and trimming the capacitors 204-1 and 204-2, so that the circuit tracks properly.

Extreme care must be taken in examining the set not to bend these coils, or to disturb the setting of these capacitors.

The 15-mmf capacitor 203 isolates the d-c grid voltage on the Tube VT-203 from a metallic ground through the grid coil 201. The 680-mmf capacitor

205-1 and 100,000-ohm resistor 206 and 560,000-ohm resistor 207 act as a filter network for the a.v.c. voltage applied to the grid. Minimum grid bias for the radio frequency tube is provided by a 330-ohm cathode resistor 208. The cathode is grounded for radio frequency through a 680-mmf by-pass capacitor 205-2. The 680-mmf capacitor 205-4 is the plate to cathode by-pass. The suppressor grid of this tube is tied directly to the cathode. The screen grid is bypassed to ground by 680-mmf capacitor 205-5 and supplied with voltage through the 39,000-ohm dropping resistor 210. The 120,000-ohm resistor 209 acts as a bleeder resistor to stabilize the screen voltage. The plate voltage is supplied through the 1000-ohm resistor 211-1. The 680-mmf capacitor 205-6, is the plate-to-ground r-f by-pass capacitor. Due to the inductive coupling of the radio frequency amplifier plate and mixer grid coils 212 and 213 the amplified signal is introduced into the mixer grid circuit.

15. CIRCUIT OF HIGH FREQUENCY OSCILLATOR.

a. The high-frequency oscillator tube is a VT-202 (9002) triode, in a modified Hartley circuit. A buffer-doubler stage is used, so the oscillator frequency is not as high, and the r-f output voltage is not as great as it would be if the oscillator were of the conventional type. This oscillator-doubler arrangement is designed to track 12 megacycles lower in frequency than the incoming r-f signal, to produce a 12 megacycle i-f frequency at the mixer.

b. The oscillator tuning coil 223 has a copper slug core that can be adjusted with a small screwdriver. This copper slug, and the trimmer capacitor 204-5, are used to align the oscillator so that it will track properly with the doubler, r-f, and the mixer stages.

The 1000-mmf capacitor 276-1 is the oscillator grid capacitor.

The 150-mmf capacitor 225 is the plate blocking capacitor and the 680-mmf capacitor 205-14 is the filament capacitor.

The 47,000-ohm resistor 226 is the grid resistor.

Since no other source of grid bias is provided, the only grid bias voltage that exists will be due to grid current.

The 4700-ohm resistor 219-2 acts as the plate dropping resistor.

This oscillator is capacity coupled through the 27-mmf capacitor 224, to the grid of the doubler stage.

16. CIRCUIT OF THE DOUBLER STAGE.

The doubler stage uses a VT-203 (9003) super-control pentode tube. The oscillator feeds directly into the untuned grid of this stage through the 27-mmf capacitor 224. The 27,000-ohm resistor 222 is the grid resistor. The plate circuit is tuned to twice the frequency of the oscillator by means of coil 214 (which is one turn of silvered copper wire) and the tuning capacitor 218A together with its trimmer capacitor 204.4.

The coupling of coil 214 to coils 212 and 213 is not very critical, so small changes in its position can be tolerated. Plate potential is applied to the tube through the 4700-ohm resistor 219-1, with the 680-mmf capacitor 205-10 as its by-pass capacitor. Screen potential is applied to the tube through the 56,000-ohm resistor 220 with the 680-mmf capacitor 205-11 as its by-pass capacitor.

Cathode bias is provided through the 560-ohm cathode resistor 221, with the 680-mmf capacitor 205-12 as the cathode by-pass capacitor.

The filament is by-passed by 680-mmf capacitor 205-13. Thus while the signal frequency circuits tune from 100-156 megacycles, the doubler tunes from 88-144 megacycles, and the high frequency oscillator tunes from 44-72 megacycles.

17. CIRCUIT OF THE MIXER STAGE.

The mixer stage uses a VT-203 (9003) super-control pentode tube. The mixing is done through the inductive coupling of coils 212, 213 and 214. The coupling between the radio frequency and mixer coils 212 and 213 is very critical, and can be varied by compressing or spreading the turns of either the r-f plate coil or the mixer grid coil.

The grid circuit, coil 213, is tuned by capacitor 202C, which is part of the three gang capacitor that tunes the grid and plate circuits of the r-f stage also.

The 47-mmf capacitor 215-1 is the grid coupling capacitor and the 1.8 megohms resistor 216 is the grid resistor.

Cathode bias is provided by the 1000-ohm cathode resistor 211-2, which is by-passed by the 680-mmf capacitor 205-7 to ground. A.v.c. grid bias is not furnished to this stage.

The screen grid voltage is supplied through the 270,000-ohm resistor 217 and is by-passed to ground by 680-mmf capacitor 205-9. Plate voltage is supplied through the 1000-ohm resistor 235-1 and the primary

of the first intermediate frequency amplifier transformer 231.

The .0068 mfd capacitors 230-1 and 230-2 by-pass the r-f from the plate circuit to ground and thereby keep the radio frequencies out of the power supply.

The three tuned circuits preceding the mixer tube, and tuned to the signal frequency increase the selectivity and thus the image rejection. Also, the high intermediate frequency of 12 megacycles results in a 24-megacycle frequency separation between the desired signal and the image. This places the image relatively far away from the peak of the resonance curve of the signal-frequency tuned circuits.

For instance, if the desired signal has a frequency of 130 megacycles, the high frequency oscillator will provide a 118-megacycle local signal, resulting in the 12-megacycle intermediate frequency. The image frequency is then 106-megacycles. However, since the three tuned circuits preceding the mixer grid are selective and tuned to 130-megacycles, the response of these tuned circuits to the image frequency of 106-megacycles will be very small.

18. CIRCUIT OF THE INTERMEDIATE FREQUENCY AMPLIFIER STAGES.

a. There are three intermediate frequency amplifier stages (four intermediate frequency transformers) used, each using a Tube VT-211 (6SG7). The intermediate frequency amplifier operates at a frequency of 12 megacycles, with a band width of 140,000 cycles at a point 6db down. The i-f transformers are semi-tuned by special high frequency 60-mmf fixed capacitors 228-1, 2, 3, 4, 5, 6, 7, and 8. These capacitors are paralleled by small 15-mmf capacitors 227-1, 2, 3, 4, 5, 6, 7, and 8, which are temperature compensating capacitors that act to keep the i-f transformers tuned to the proper i-f frequency when the set is subjected to temperature variations. The final tuning of the i-f transformers is done by adjusting the special powdered iron-cores in the coils themselves.

b. Grid bias voltage for the i-f stages is obtained from three sources.

(1) Each stage has its own 220-ohm cathode resistor 237-1, 237-2, and 237-3 and associated .0068-mfd cathode capacitor 230-4, 230-8, and 230-12 which develops a certain fixed cathode voltage on each tube, depending on the cathode circuit of each tube.

(2) Grid bias voltage is developed across the 300-ohm THRESHOLD SENSITIVITY control 241

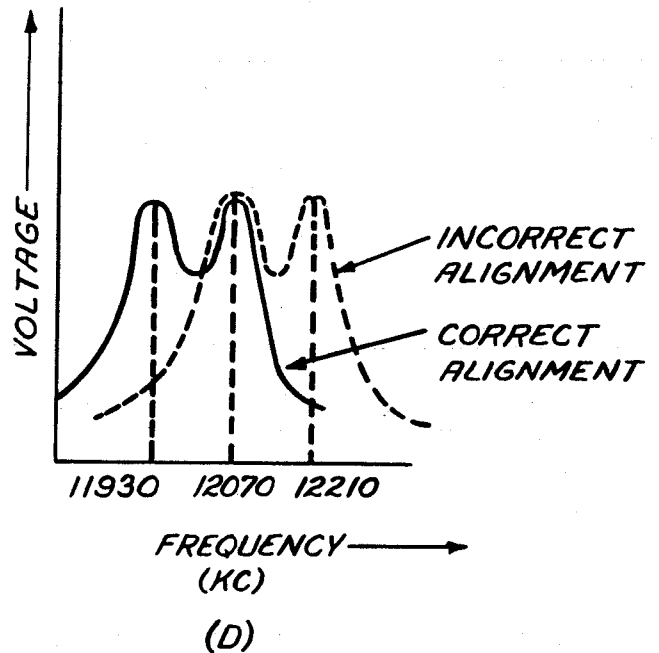
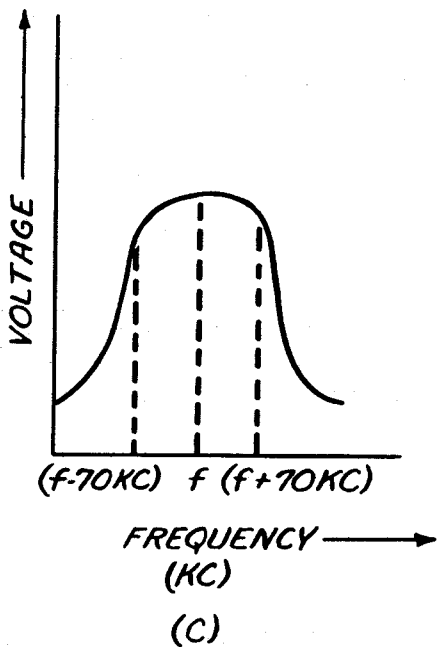
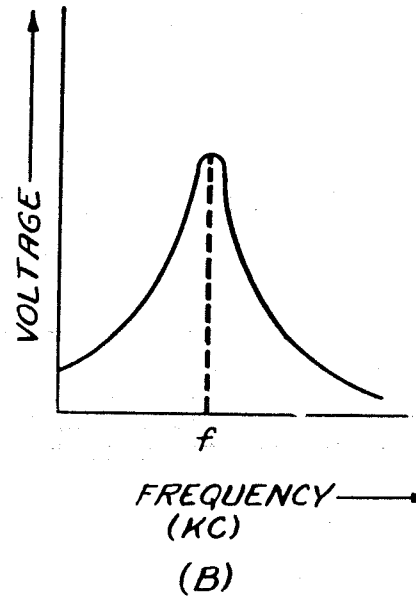
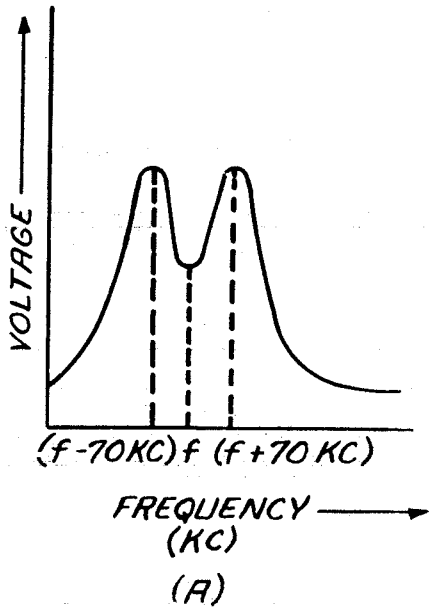

INTERMEDIATE FREQUENCY RESPONSE CURVES

Figure 7 — Intermediate Frequency Response Curves

when the C.W. AND MANUAL, MANUAL, A.V.C. switch is on A.V.C. The grid bias voltage appears across the THRESHOLD SENSITIVITY control 241 and the R.F. GAIN INCREASE control 242 when this switch is at C.W. MANUAL or MANUAL. The setting of the THRESHOLD SENSITIVITY control determines the overall gain of the i-f amplifier. This THRESHOLD SENSITIVITY control is set at the factory and should very seldom need adjusting, except to compensate for sensitivity loss due to tube life, since in all positions but the A.V.C. position the 3000-ohm R.F. GAIN INCREASE control 242 will also vary the overall gain of the i-f stages as well as the first r-f stage. THRESHOLD SENSITIVITY and R.F. GAIN INCREASE controls 241 and 242 are by-passed by 1.0 mfd capacitor (239-1).

(3) The third source of grid bias voltage is an a.v.c. voltage, which is applied to the first r-f stage through the 100,000-ohm resistor 206 and the 560,000-ohm resistor 207 and also the first and second i-f stages through 100,000-ohm resistors 236-1 and 236-2 respectively. The 680-mmf capacitor 205-1, and the two .0068-mfd capacitors 230-3 and 230-7 are the respective grid by-pass capacitors for the above resistors. A.V.C. voltage is developed in the second detector stage, and will be discussed under the next heading. The screen grid voltage is applied through 47,000-ohm screen dropping resistors 238-1, 238-2 and 238-3 respectively with .0068-mfd capacitors 230-5, and 230-9, and 230-14 respectively, acting as screen grid by-pass capacitors.

Plate voltage is applied to each stage through the 1000-ohm plate resistors 235-2, 235-3 and 235-4 respectively, the plate voltage for each stage passing through the primary winding of the following stage. The .0068-mfd capacitors 230-6, 230-10 and 230-15 are plate r-f return by-pass capacitors. Only the filament of the third i-f stage is by-passed by the .0068-mfd capacitor 230-13.

c. The plate current of the first intermediate frequency amplifier is measured by 0-10 milliampere TUNING METER 240. The plate current of this tube varies inversely with the a.v.c. voltage applied to the grid of the first intermediate frequency tube through the 100,000-ohm resistor 236-1 and the secondary coil of the first intermediate frequency transformer 231. Since the a.v.c. voltage varies with the signal strength, this meter will give an indication of the strength of the incoming signal. *The greater*

the strength of the input signal, the greater will be the a.v.c. voltage developed and thus the greater will be the bias applied to the grid of the first i-f tube. This will result in a decrease in plate current of the first i-f tube and hence a decrease in the meter reading. Therefore, the lower the meter reading the greater the input signal strength.

d. The first two intermediate frequency transformers are over-coupled, giving a double-humped frequency-response curve, with peaks occurring 70 kilocycles each side of 12 megacycles. The combination of the four transformers provides a 12-megacycle, band-pass response curve 140-kilocycles wide. This characteristic gives good selectivity while providing a band-pass sufficiently wide that the receiver will remain in tune despite small variations that may occur in signal frequency or in the receiver high-frequency oscillator. Figure 7a shows the double-peaked response curve for the first two i-f transformers and figure 7b shows the sharp response curve for the last two i-f transformers. The overall resulting response curve figure 7c will be a comparatively flat band-pass, about 140-kilocycles broad.

In the alignment instructions, after the 4th and 3rd i-f transformers are peaked at 12 megacycles, you are instructed to peak the 2nd and 1st i-f transformers at the frequency of 12070 kilocycles which corresponds to the frequency of the right hand peak present in the transformer's response curve. After alignment of both the 2nd and 1st i-f stages at the 12070 kilocycles setting, the same procedure is carried out for 11930 kilocycles.

Reference to figure 7d will show why these first two stages must be aligned separately for 12070 kilocycles and 11930 kilocycles. It is possible that when adjusting the 1st two i-f transformers to peak at 12070 kilocycles, the peak you get will be at 12070 kilocycles but will be the left-hand peak, with the right-hand peak 140 kilocycles away at 12210 kilocycles. To check that the peak at 12070 kilocycles is definitely the right peak, you feed a 11930 kilocycles signal in, and you adjust the iron core for maximum response. If the setting of the iron-core is about the same for 11930 kilocycles as for 12070 kilocycles, you are then sure that the response of the 1st and 2nd i-f transformers is the desired response, peaking plus and minus 70 kilocycles on each side of 12,000 kilocycles.

19. CIRCUIT OF THE SECOND DETECTOR, FIRST AUDIO, A.V.C. STAGE.

a. The second detector, first audio, a.v.c. stage uses a dual diode-triode VT-103 (commercial type 6SQ7) tube. One diode acts as a half-wave rectifier type detector, and the other diode gives the a.v.c. voltage, while the triode acts as the first-audio stage. The 47-mmF capacitor 215-2 is connected directly between the diode plates of the tube. So as far as r-f voltage (or i-f voltage) is concerned the diode plates are tied together electrically, but as far as the detected audio frequency, or detected a.v.c. voltage is concerned the diode plates are separated electrically. The r-f (i-f) voltage is applied to the diodes through the diode that is directly connected to the secondary of the 4th i-f transformer.

From detector theory it can be shown that several harmonic frequencies, plus pulsating d-c (audio-frequency), plus a d-c component are produced by diode detection. These components will appear in the circuit of each diode plate. In the circuit of the diode plate connected directly to the secondary of the 4th i-f coil, the 47-mmF capacitor 215-2, the 1.8-mmF capacitor 246 and the 330-mmF capacitor 245-1 are too small to pass anything but r-f, but capacitor 245-1 will ground most of the r-f at this point, leaving the rectified (modulating) frequency, plus a d-c voltage that will appear across the 100,000-ohm resistors 236-4 and 236-5. The 220-mmF capacitor 247 across the 100,000-ohm resistor 236-5 further reduces the r-f voltage across resistor 236-5. The audio frequency developed across resistor 236-5 goes through the .0068-mfd blocking capacitor 230-17 and appears across the 1-megohm potentiometer 251, which acts as audio volume control and grid resistor for the first audio stage.

b. The second diode plate is used to produce a.v.c. voltage. Most of the rectified voltage from this plate appears across 1-megohm resistor 244-1. To be useful a.v.c. voltage has to be d-c voltage. Therefore 1-megohm resistor 244-2 and .0068 mfd capacitor 230-16 act as a filter to remove practically all components of the detector voltage but the d-c component. This voltage is fed to the first r-f stage through the 100,000-ohm resistor 206 and 560,000-ohm grid resistor 207, by-passed by the 680-mmF capacitor 205-1; to the first i-f stage through the 100,000-ohm resistor 236-1, by-passed by the .0068 mfd capacitor 230-3; and to the second i-f stage through the 100,000-ohm resistor 236-2, by-passed by the .0068-mfd capacitor 230-7. These resistor-

capacitor combinations are very effective as filters, since the grid circuit draws very little current. They remove practically all but the d-c from the a.v.c. bus and very effectively decouple the stages connected to the a.v.c. bus.

c. The triode unit of this stage functions as the first audio stage. As we have seen above the audio signal is fed through from the detector to the audio volume control, 1-megohm resistor 251, which functions as the grid resistor. The grid bias voltage for this stage is developed across 18,000-ohm resistor 249 and 2200-ohm resistor 250, by-passed by 0.1-mfd capacitor 248 in the cathode circuit. The delay action of the a.v.c. circuit is determined by 18,000-ohm resistor 249. The plate load consists of 68,000-ohm resistor 252, and two 33,000-ohm resistors 253-1 and 253-2. These resistors are connected to three position switch 254, forming an audio attenuator that is used to regulate the audio output level. The 330-mmF capacitor 245-2 in the plate circuit of the first audio stage is used to ground any r-f voltage that might have leaked through the second detector circuit.

20. CIRCUIT OF THE C-W OSCILLATOR STAGE.

The c-w oscillator uses a VT-211 (6SG7) pentode tube. The circuit is a little unusual in that the grid circuit is tuned to one half the i-f frequency, or 6 megacycles, while the plate circuit is tuned to the first harmonic of the oscillator frequency or 12 megacycles. This is done to prevent the c-w oscillator from "locking in" with the i-f frequency, and thus failing to function as a c-w oscillator. The circuit is a type of electron coupled oscillator.

The grid circuit is tuned by coil 269 and 390-mmF capacitor 271 and variable capacitor 270 (C.W. TONE CONTROL).

The 1000-mmF capacitor 276-2 is the oscillator grid blocking capacitor. The 47,000-ohm resistor 238-4 is the grid resistor. The .0068-mfd capacitor 230-20 is the plate r-f bypass capacitor. The screen-grid of the tube acts as the plate for the oscillating circuit. High voltage is supplied to the screen grid through 47,000-ohm resistor 268 and a tap on coil 269. The plate circuit of the tube is connected to the oscillator through the electron stream in the tube itself, and is tuned to 12 megacycles by coil 266 and by 100-mmF capacitor 265.

The final tuning of the plate circuit is done by the adjustment of an iron-core in the coil 266. The output of the c-w oscillator is fed to the diode detector plate that is tied to the secondary of the

last i-f transformer through 1.8-mmf capacitor 246 and 4.7-mmf capacitor 267. These two capacitors are used in series to reduce the load on the oscillator and to prevent too much interaction between circuits. The frequency of the beat frequency oscillator is variable slightly above and below 12 megacycles and since the intermediate frequency feeding the second detector is 12 megacycles, this will produce an audible beat (tone) in the output. The frequency of the beat note will be the difference between the beat frequency oscillator frequency and the intermediate frequency and may be varied by adjusting the C.W. TONE CONTROL knob on the front panel.

21. CIRCUIT OF THE SECOND AUDIO STAGE.

The second audio stage uses a VT-152(6K6-GT/G) pentode tube. The circuit is that of the usual resistor-capacitor coupled pentode amplifier. Grid bias voltage is developed across 560-ohm cathode resistor 256, by-passed by 1.0 mfd capacitor 239-2. The grid bias on this tube is purposely made a little high to reduce the gain and power output of this stage, in order to prevent the plate from drawing more than 60-ma. current. The 330,000-ohm resistor 255 is the grid return resistor, and .0068-mfd capacitor 230-18 is the coupling capacitor from the plate circuit of the first audio stage. Screen grid voltage is supplied directly from the high voltage supply for the receiver.

The plate of the second audio stage works into the primary of transformer 258, which is used to match the impedance of the plate circuit to the impedance of the line. This transformer is designed to work into a 600-ohm line, but it will work satisfactorily into an impedance of from 200 to 10,000 ohms. The .0068-mfd capacitor 257 is used to peak the response of transformer 258 to 1000 cps., which is the most useful audio frequency of this set. The transformer 258 has a balanced output and an electrostatic shield between its windings to insure that the receiver output circuit is suitable for the direct connection to the telephone line circuit. The 4700-ohm resistor 261 is used to ground the center of the transformer, since neither side of the line is grounded.

The secondary of the transformer 258 is connected to two jacks 262-1 and 262-2 and to line terminals Nos. 11 and 12. Jack 262-1 is the MONITOR jack while jack 262-2 is the LINE jack. Plugging into LINE jack 262-2 will open both leads to the line terminals Nos. 11 and 12, thus cutting off the line

to the silence cabinets.

22. SHIELD CANS.

The following units are enclosed in separate shield cans: (fig. 16)

- a. Four i-f transformers and their associated capacitors.
- b. The output transformer.
- c. The entire oscillator-doubler unit.
- d. The primary coil tuning assembly of the c-w oscillator.

23. FUNCTION OF OPERATING CONTROLS.

a. MAIN TUNING CONTROL.—The main tuning control is a large knob that rotates a lighted dial marked, MEGACYCLES. The dial, calibrated to read directly in megacycles, is behind a window in the front panel and only a small part of it can be seen. This control drives the five tuning capacitors which are ganged three on one gang and two on one gang.

The three gang capacitor consists of the tuning capacitor for the grid of the radio frequency stage, the plate of the radio frequency stage and the grid of the mixer stage.

The two gang capacitor tunes the oscillator and doubler plate circuits. These two gangs are connected together by anti-backlash gears. The dial light 273 is located behind the front panel and at the left side of the scale.

b. THRESHOLD SENSITIVITY.—The THRESHOLD SENSITIVITY control is a 300-ohm linear rheostat. It is reached by first removing the slotted plug from the front panel which uncovers the screwdriver adjustment of the control. This control is adjusted to about 5-ma with the R.F. GAIN INCREASE control full ON, and is used to increase the gain of the receiver when it is low.

c. R.F. GAIN INCREASE.—The R.F. GAIN INCREASE control gives manual radio frequency gain control by means of a 3000-ohm rheostat in the cathode circuit of the first radio frequency tube. This control is grounded out when the C.W. AND MANUAL, MANUAL, A.V.C. switch is turned to A.V.C. When the receiver is being used for direction finding purposes the signal is kept at a comfortable level by means of the R.F. GAIN INCREASE in order to avoid overloading and get a sharp minimum.

d. C.W. AND MANUAL, MANUAL, A.V.C.—This switch has three positions marked C.W. AND MANUAL, MANUAL, A.V.C. It is used to select the position which determines whether the function of the receiver is to be communication or direction finding. When at C.W. AND MANUAL the beat frequency oscillator is supplied screen and plate voltages, giving an audio tone in the output when a signal is tuned in. In this position the A.V.C. is cut out, thus making the control of the receiver gain entirely manual. This setting is used in taking D/F bearings and for locating weak signals. In the MANUAL position the beat frequency oscillator is OFF, the A.V.C. is cut out and the control of the receiver gain is entirely manual, so that the D/F bearings can be taken on normal signals. When at A.V.C. the beat frequency oscillator is OFF and the automatic volume control functions normally, making this setting suitable for radio telephone communication. In this position fading is minimized and the output practically constant regardless of variations in carrier signal strength. The R.F. GAIN INCREASE control is out of the circuit and the volume is controlled by the AUDIO GAIN INCREASE control and the ATTENUATION control.

e. AUDIO GAIN INCREASE.—The AUDIO GAIN INCREASE control (251) consists of a 1-megohm potentiometer connected in the input circuit of the 1st audio portion of the second detector, and is adjusted to control the audio input to the audio amplifier stages.

f. ATTENUATION.—The ATTENUATION control is a three-position switch (—12 DB, —6 DB, 0 DB) which attenuates the audio level down to 12 db below normal by the connections to a resistance network in the output of the 1st audio amplifier stage. It determines the maximum audio output but is normally left at 0 DB.

g. C.W. TONE CONTROL.—The C.W. TONE CONTROL knob controls a variable capacitor 270 in the beat frequency oscillator circuit. This control changes the frequency of the oscillator slightly, resulting in a change in the pitch of the beat note.

h. MONITOR JACK.—The MONITOR jack is a bridging jack. By inserting a headphone plug into this jack you will place the headphones across the line with no interruption of the externally connected line.

i. LINE JACK.—The LINE jack is a lifting jack. By inserting a headphone plug into this jack, the phones will be connected to the output of the receiver but the external line will be automatically disconnected.

j. TUNING METER.—The TUNING METER is a DC milliammeter in the plate circuit of the first intermediate frequency stage which functions only when the C.W. AND MANUAL, MANUAL, A.V.C. control is at A.V.C. The meter indicates minimum current when the receiver is tuned to a signal as well as the relative signal strength of various carriers. A weak signal gives a small deflection and a strong signal a large deflection on the meter.

SECTION V
MAINTENANCE

24. GENERAL.

Before removing a component from Radio Receiver BC-639-A find out the cause of failure and the particular faulty component or circuit of the equipment. **LOOK FOR THE SIMPLE CAUSES OF TROUBLE FIRST.**

Many defects can and may develop in a complex piece of radio equipment. Remember that time can

always be saved by finding out the *cause* of trouble and the sub-assembly or component that is to blame.

Study the complete schematic circuit diagram and check the various possible causes of failure. When you have detected the bad unit, beyond a reasonable doubt, remove and repair it or replace it with a good unit.

A suitable dummy antenna for testing Radio Receiver BC-639-A is electrically the same as a

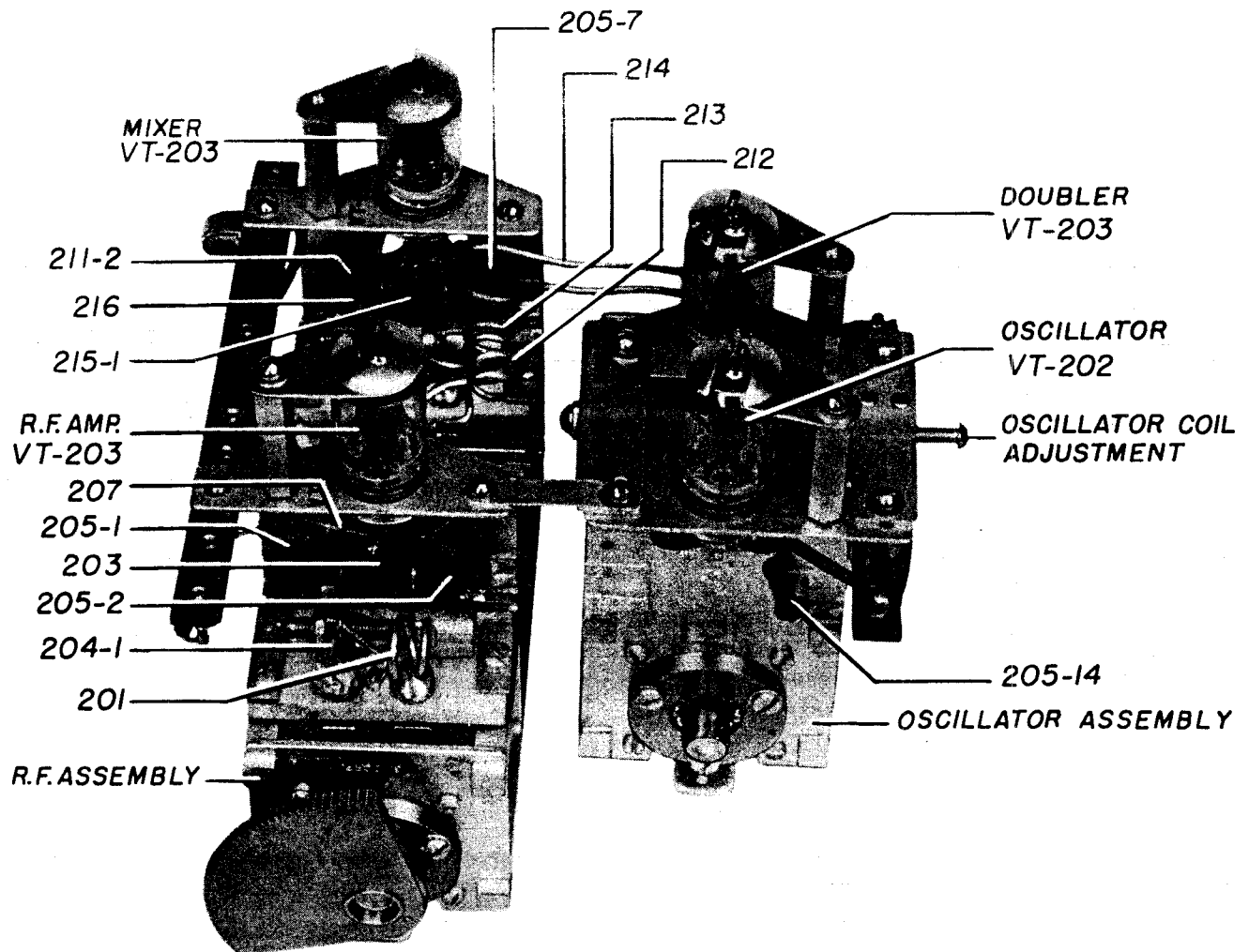

Figure 8 — Radio Receiver BC-639-A, Top Front Oblique, R. F. and Oscillator Assembly

70-ohm line. If the signal generator used for testing the equipment has an output impedance of about 14 ohms, a 50-ohm ± 5 per cent, non-inductive resistor placed in series with the "hot" side of the generator should be used.

25. OPERATIONAL INSPECTION.

The inspection of Radio Receiver BC-639-A should be thorough enough to determine whether or not the equipment is in proper and good working order. The operating tests should be made either in the station with which the receiver is to be used, or under the conditions where the test location, the set up of the receiver, and the operating conditions of the receiver will be as close as possible to those of the station with which the receiver is to operate. If the test is made in the station, the receiver should be left in Frame FM-39. For all other inspections or tests, first remove the receiver from Frame FM-39 as instructed in paragraph 26b, section V of this book and then go ahead with the test or inspection.

NOTE

For details of how to operate the receiver in each station see the instruction book for the radio set with which Radio Receiver BC-639-A will be operated.

a. See that all plugs are securely seated. Check headset cords. Clean all headset plugs. (A three-inch pencil eraser provides a simple means for cleaning these plugs.)

b. Be sure that the dial light glows when power is supplied to the receiver.

c. Check the power supply of the receiver. You can find out all about the power supply, either Rectifier RA-42-A, (or Rectifier RA-42-B) or Dynamotor Unit PE-100-A, in the separate instruction book for each of these units. If Dynamotor Unit PE-100-A is to be used, check the storage battery supplying this unit. Be certain that it is fully charged and supplies at least 5.5 volts to the dynamotor when operating at full load.

d. Switch the power to Radio Receiver BC-639-A ON so that the receiver is operating normally. If no station signals are available, Frequency Meter BC-638-A or Oscillator Test Equipment RC-93-A may be used to give a signal for the operating test. (Refer to the instruction book for each of these units for operating instructions if they are to be used.)

(1) Check the operation of all controls on the front panel.

(2) Check the noise level of the receiver. It should be about 5-10 mw (1.78 to .45 volts across a 600-ohm non-inductive load) with no signal input and gain controls at maximum. (See paragraph 38.)

(3) Check the receiver sensitivity with instructions given in paragraph 37.

(4) Check the frequency calibration with Frequency Meter BC-638-A.

(5) Check the TUNING METER. (It should read about 5 milliamperes with the R.F. GAIN INCREASE control all the way to the right and with no signal input to the receiver.)

26. DISASSEMBLY OF UNIT.

a. POWER AND ANTENNA CONNECTIONS.—The power supply cable and the 70-ohm coaxial antenna transmission line are disconnected from the RADIO RECEIVER BC-639-A by removing the plugs from their respective sockets at the rear of the receiver chassis.

b. TO REMOVE RADIO RECEIVER BC-639-A FROM STANDARD RACK MOUNTING.—Release the six roundhead machine screws which pass through the three slots at each side of the panel.

Support the unit from the front panel and remove the six screws.

Grasp the handles and lift the unit out of the frame from the front.

Remove the two bottom screws last.

Be careful not to jar the unit when removing it from the rack as jarring may injure the vacuum tubes, especially those of the 9000 series. (VT-202 and VT-203).

c. TO REMOVE DUST COVER FROM THE CHASSIS.—Unscrew the five screws along the top front edge of the dust cover *behind* the front panel.

Unscrew the two screws at each edge of the rear surface of the dust cover.

Unscrew the three screws around the antenna terminal.

A #6 Allen wrench is mounted on the chassis right rear of each receiver for Allen setscrews in the drive assembly, couplings, knobs etc.

d. TO REMOVE ELECTRICAL ASSEMBLIES FROM CHASSIS.

(1) OSCILLATOR ASSEMBLY.—Remove the oscillator assembly (274) from the chassis as follows: (**BE VERY CAREFUL NOT TO DAMAGE IT WHILE REMOVING.**)

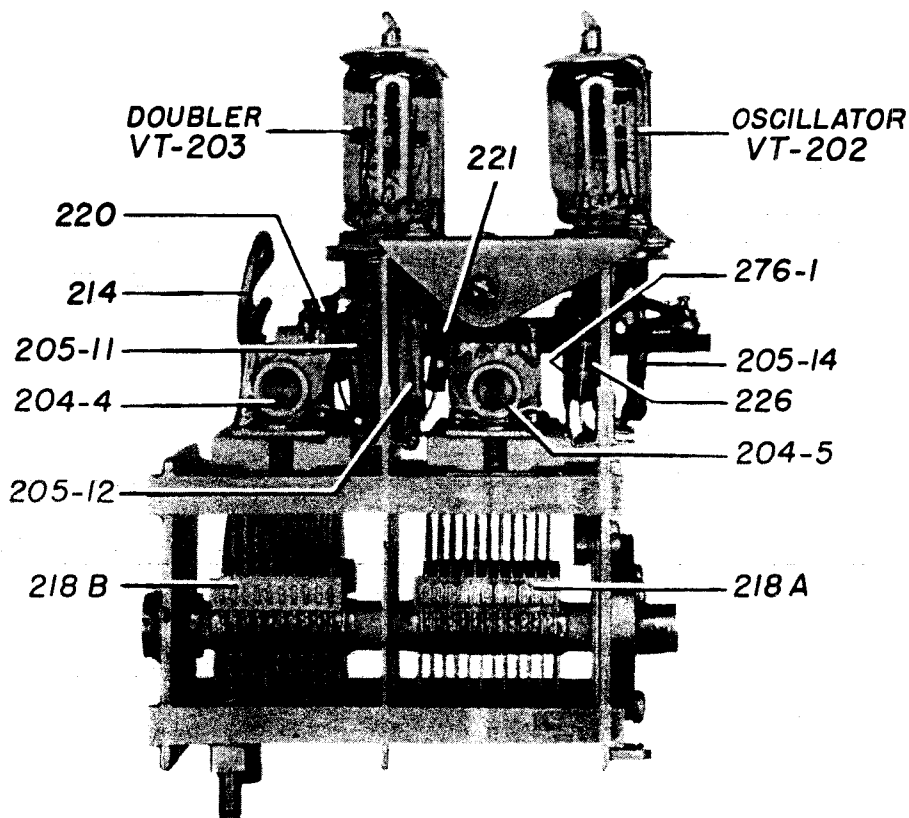

Figure 9 — Radio Receiver BC-639-A, Left Side View, Oscillator Assembly

(a) Facing the front panel, locate the two wires, one red and one brown, coming to the terminal strip on the top of right side of the oscillator tuning gang from below the chassis. Unsolder these two wires from the terminal strip, *making a careful note of where they are connected.*

(b) Remove the small ground strap connecting the radio frequency tuning gang and the oscillator tuning gang. This strap is located between the oscillator and r-f. Amplifier tubes on the top front of the two capacitor gangs. This strap is held at each end by a small screw with plain washer.

(c) Loosen the two adjacent (on the same coupler) Allen setscrews in the flexible coupler which connects the capacitor shaft to the drive assembly. (To loosen the setscrews use the Allen wrench mounted on the receiver chassis.)

(d) Remove the two nuts and one screw below the chassis which hold the oscillator assembly to the chassis.

(e) Lift up and back, until the capacitor shaft clears the coupler and then remove the assembly from the receiver.

(2) RADIO FREQUENCY ASSEMBLY.— Remove radio-frequency assembly (275) from the chassis as follows: **CAUTION: BE CAREFUL NOT TO DAMAGE IT WHILE REMOVING. BE VERY CAREFUL NOT TO BEND ANY OF THE COILS AND DO NOT TOUCH THE TRIMMER CAPACITORS.**

(a) Locate the four wires coming from below the chassis to the terminal strip on the left side of the radio frequency tuning gang. Unsolder these wires from the terminal strip. *Make a careful note of where they are connected.*

(b) Locate the two wires coming from the first intermediate frequency transformer (Ref. No. 231) to the radio frequency assembly. Unsolder these wires after *making a careful note of where they are connected.*

(c) Locate the two red wires coming from below the chassis to the corner of the terminal board. Unsolder these wires after *making a note of where they are connected.*

(d) Locate the antenna lead-in pipe. Unsolder the antenna wire and the antenna shielding pipe from the radio frequency assembly.

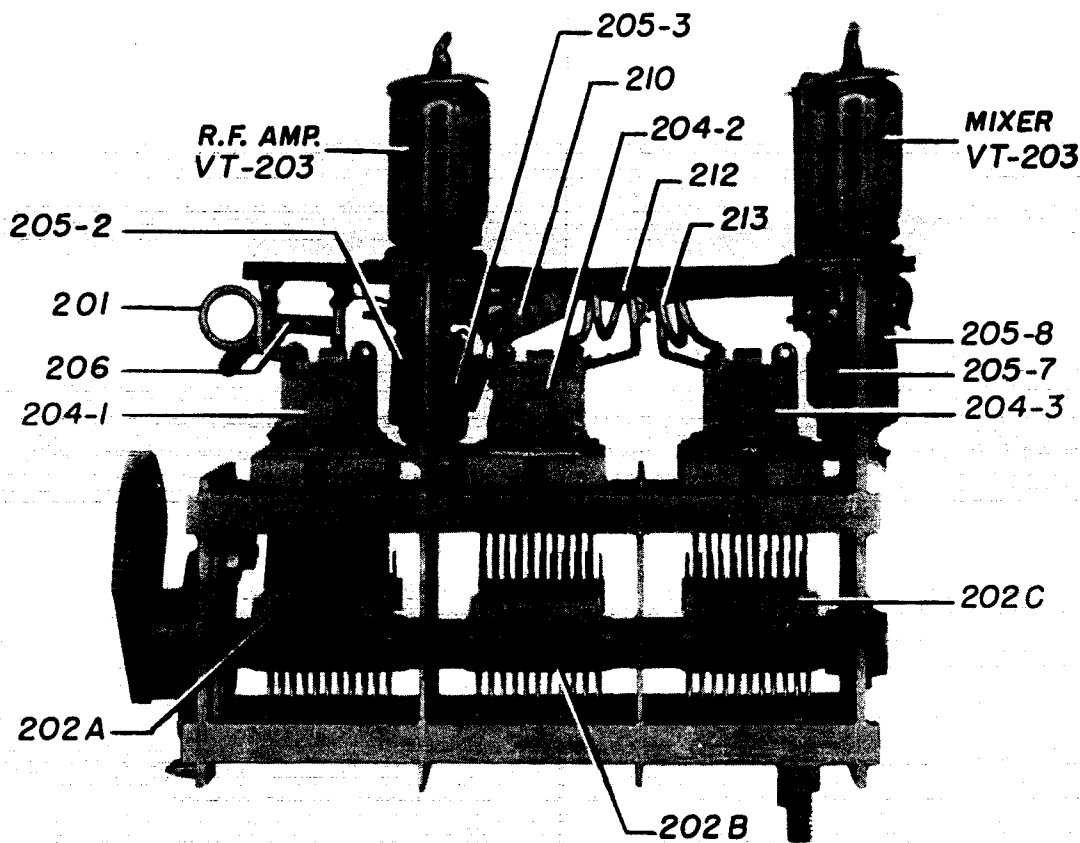

Figure 10 — Radio Receiver BC-639-A, Right Side View, R. F. Assembly

(e) Remove the small ground strap connecting the radio-frequency tuning gang to the oscillator tuning gang. This strap is at the top of the tuning gangs and is held by a screw with a plain washer at each end of the strap.

(f) Remove the two nuts and one screw, below the chassis, which hold the radio frequency assembly to the chassis.

(g) Slide the complete radio-frequency assembly toward the rear of the receiver, disengaging the two quadrant gears.

(h) Lift the assembly out of the receiver chassis.

NOTE

Remove the oscillator assembly from the receiver chassis before removing the radio-frequency assembly. In this way the edge of the radio-frequency assembly is moved to one side, thus clearing the antenna lead-in pipe.

(3) INTERMEDIATE FREQUENCY TRANSFORMER ASSEMBLIES.—First intermediate frequency transformer.

Unsolder all wires connected to the four terminals on the bottom of the chassis.

On the first intermediate frequency transformer unsolder the two wires on the top of the chassis, one of which is connected to the grid of the mixer tube and the other to the three gang capacitor frame.

Remove the two #6-32 hexagonal nuts and lift the assembly from the top of the chassis.

(4) SECOND, THIRD, FOURTH INTERMEDIATE FREQUENCY TRANSFORMER ASSEMBLIES.—Unsolder all wires leading to each of the four terminals on the bottom of the chassis.

Remove the two #6-32 hexagonal nuts.

Lift the assembly from the top of the chassis.

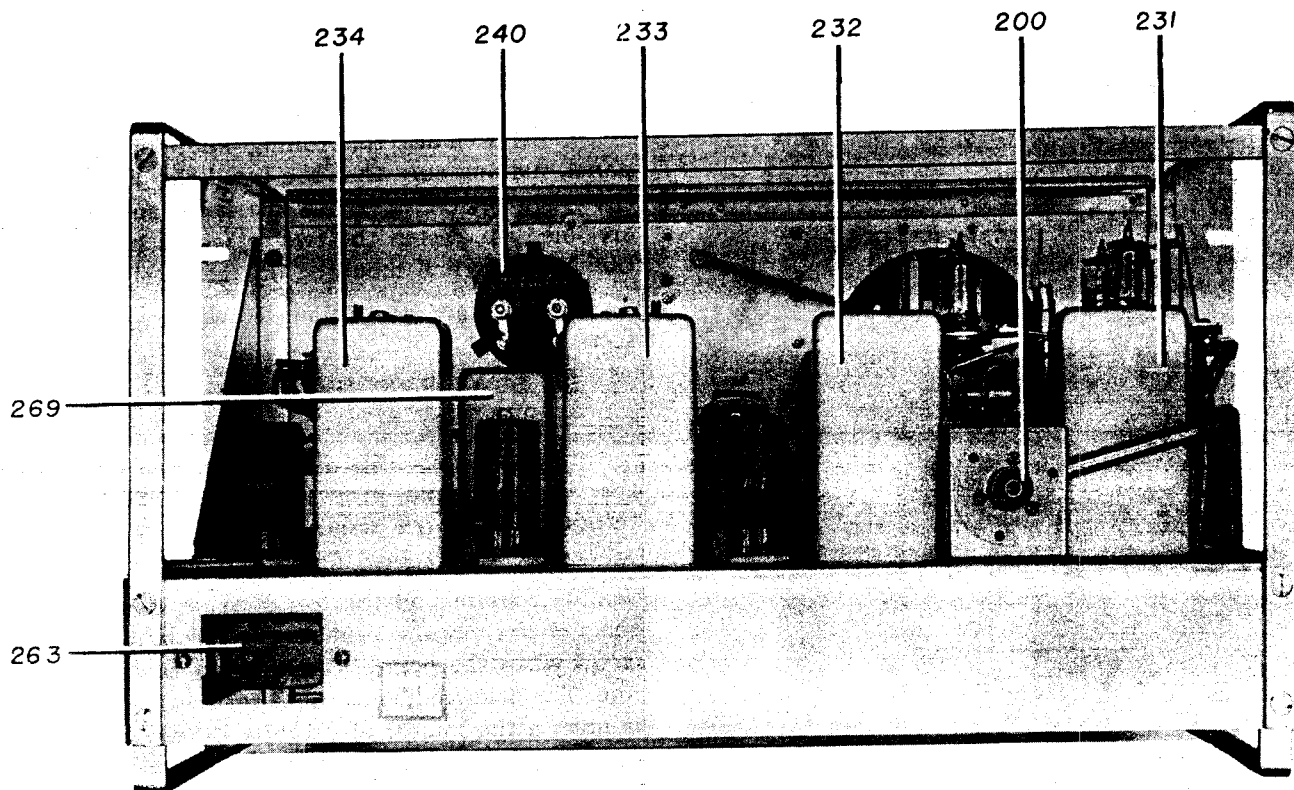

3131

Figure 11 — Radio Receiver BC-639-A, Rear View, Dust Cover Removed

Make a careful note of the way the four transformer cans are placed on the chassis of the receiver, the 1st and 4th transformer cans are placed so that the terminals #3 and #4 are next to the back of the receiver chassis. The second and third transformer cans are placed so that terminals #1 and #2 are next to the back of the receiver chassis.

(5) BEAT FREQUENCY OSCILLATOR ASSEMBLY (272).—Unsolder the wires from the three terminals of the oscillator assembly can and remove the two #6-32 round-head screws.

Loosen the two Allen setscrews in the flexible coupling on the top of the chassis. (*An Allen wrench is mounted on the chassis for this purpose.*)

The assembly may now be removed from the top side of the chassis.

(6) GEAR DRIVE ASSEMBLY.—A large tuning control knob on the front panel must be removed before the gear drive assembly can be removed from the chassis. This knob has two holes, set at a 90° angle, cut into its side.

The knob must be turned against its clutch until the holes line up and an Allen setscrew can be seen by looking down into each hole.

When the holes are lined up with the setscrews, the Allen wrench, mounted on the receiver chassis, may be inserted and the two #6-32 Allen setscrews loosened.

Remove this knob from the front panel.

Remove the dial light which is held firmly in place by two screws and oversize lockwashers, fastening into a slot for easier adjustment.

Remove the three binder-head screws on the front panel which hold the casting in place.

Remove the anti-backlash spring from the dial tie wire.

Loosen the setscrews on the coupling of the two gang assembly.

Lift the complete gear drive assembly from the receiver.

(7) AUDIO TRANSFORMER ASSEMBLY (258).—Unsolder all the wires from the five terminals on the bottom of the chassis.

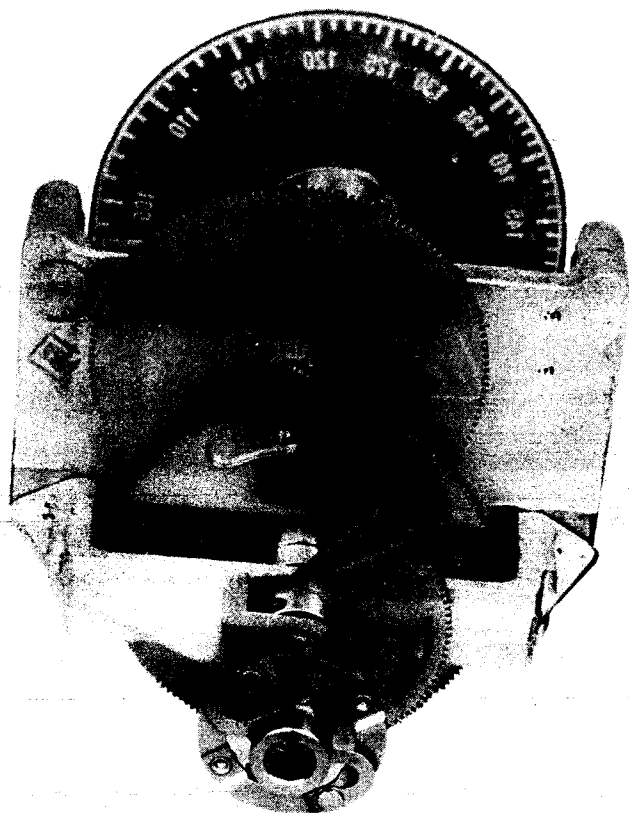

Figure 12 — Radio Receiver BC-639-A,
Dial Drive Gears

Remove the four #6-32 round-head mounting screws and lift the transformer from the chassis.

27. REASSEMBLY OF UNIT.

a. TO REPLACE ELECTRICAL ASSEMBLIES ON CHASSIS.

(1) AUDIO TRANSFORMER ASSEMBLY (258).—Replace the transformer can in the chassis; be very careful to get it just as shown in the wiring diagram.

Resolder all wires to the five terminals on the bottom of the chassis, these connections are shown in the wiring diagram.

Replace the four #6-32 roundhead mounting screws which hold the transformer to the chassis.

(2) GEAR DRIVE ASSEMBLY.

(a) Replace the gear drive assembly in the receiver chassis and tighten the setscrews on the coupling of the two gang assembly.

(b) Replace the anti-backlash spring on the dial tie wire.

(c) Replace the three binder-head screws on the front panel which hold the casting in place.

(d) Replace the dial light, fastening tightly the two screws and oversize lockwashers.

(e) Replace the tuning knob on the front panel, making sure that the two holes line up with the Allen setscrews. When the holes and setscrews are lined up, fasten the two setscrews by means of the Allen wrench mounted on the receiver chassis.

(f) Align as explained in paragraph 34c., section V.

(3) BEAT FREQUENCY OSCILLATOR ASSEMBLY (272).

(a) Replace this assembly on the top side of the chassis, making proper connections to the three terminals. (See the wiring diagram, fig. 24)

(b) Tighten the two Allen setscrews, in the flexible coupling on the top of the chassis, so that the red line on the beat frequency oscillator shaft is up when the pointer of the knob is on the index line. The beat frequency oscillator variable capacitor is now in the middle of its capacity range.

(c) Replace and tighten the two #6-32 round-head screws, which hold the assembly in the chassis.

(4) INTERMEDIATE FREQUENCY TRANSFORMER ASSEMBLIES.—In replacing the first and fourth transformer cans in the chassis be sure that terminals 3 and 4 are next to the back

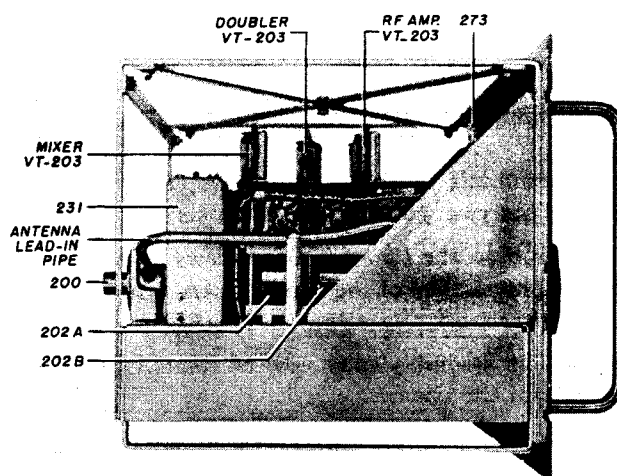

Figure 13 — Radio Receiver BC-639-A,
Left Side View

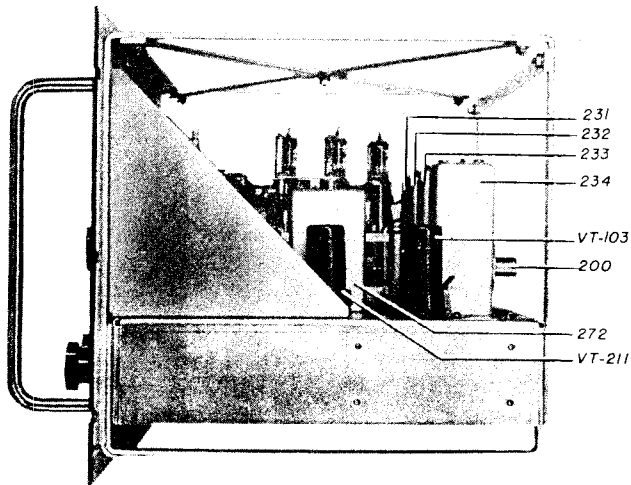

Figure 14 — Radio Receiver BC-639-A,
Right Side View

of the receiver chassis. In replacing the second and third transformer cans be sure that terminals 1 and 2 are adjacent to the back of the receiver chassis.

When the transformer cans are properly set resolder all wires connected to the four terminals at the bottom of the chassis.

Replace the two #6-32 hexagonal nuts which hold the assemblies to the chassis.

In replacing the first transformer assembly resolder the two wires on the top of the chassis (coming from the side of the can), the green wire is connected to the grid of the mixer tube and the other wire is connected to the three gang capacitor frame.

CAUTION

DO NOT TIGHTEN SPADE PLUGS TOO TIGHTLY AS THEY WILL TWIST OFF THE ASSEMBLY.

After reasonably tight and approximate intermediate frequency transformer assemblies as described in paragraph 34a., section V.

NOTE

It is very important that all intermediate frequency transformers are properly placed with reference to the terminal numbers on the bottom of the assembly. (See paragraph 34a., section V and the wiring diagram fig. 24.) The first and second intermediate frequency trans-

formers are *over-coupled* but are not otherwise similar. The third and fourth transformers are *critically-coupled* and are exactly alike except for stenciling. They may be interchanged if properly placed on the chassis.

(5) OSCILLATOR ASSEMBLY (274).

(a) Replace the oscillator assembly in the chassis making sure that the capacitor shaft is inserted in the coupler.

(b) Replace the two nuts and one screw below the chassis which hold the oscillator assembly to the chassis.

(c) Tighten the two Allen setscrews next to it in the flexible coupler which connects the capacitor shaft to the drive assembly.

(d) Replace the ground strap connecting the radio frequency tuning gang and the oscillator tuning gang.

(e) Fasten the small screw and washer which hold the strap at each end.

(f) Replace the two wires (*one red and one brown*) coming to the terminal strip on the top-right side of the oscillator tuning gang from below the chassis.

(g) Align the oscillator assembly in connection with the radio frequency assembly as explained in paragraph 34d., section V.

(6) RADIO FREQUENCY ASSEMBLY (275).

(a) Replace the radio frequency assembly in the receiver chassis making sure that the two ground straps are attached.

(b) Replace the two nuts and one screw, (below the chassis) which hold the radio frequency assembly to the chassis.

(c) Replace the ground strap connecting the radio frequency tuning gang to the oscillator tuning gang. This strap is held by a screw and plain washer at each end of the strap.

(d) Resolder the antenna wire and antenna shielding pipe to the assembly.

(e) Resolder the two *red* wires coming from below the chassis to the corner of the terminal board located at the left side of the radio frequency assembly.

(f) Resolder the two wires coming from the first intermediate frequency transformer to the radio frequency assembly.

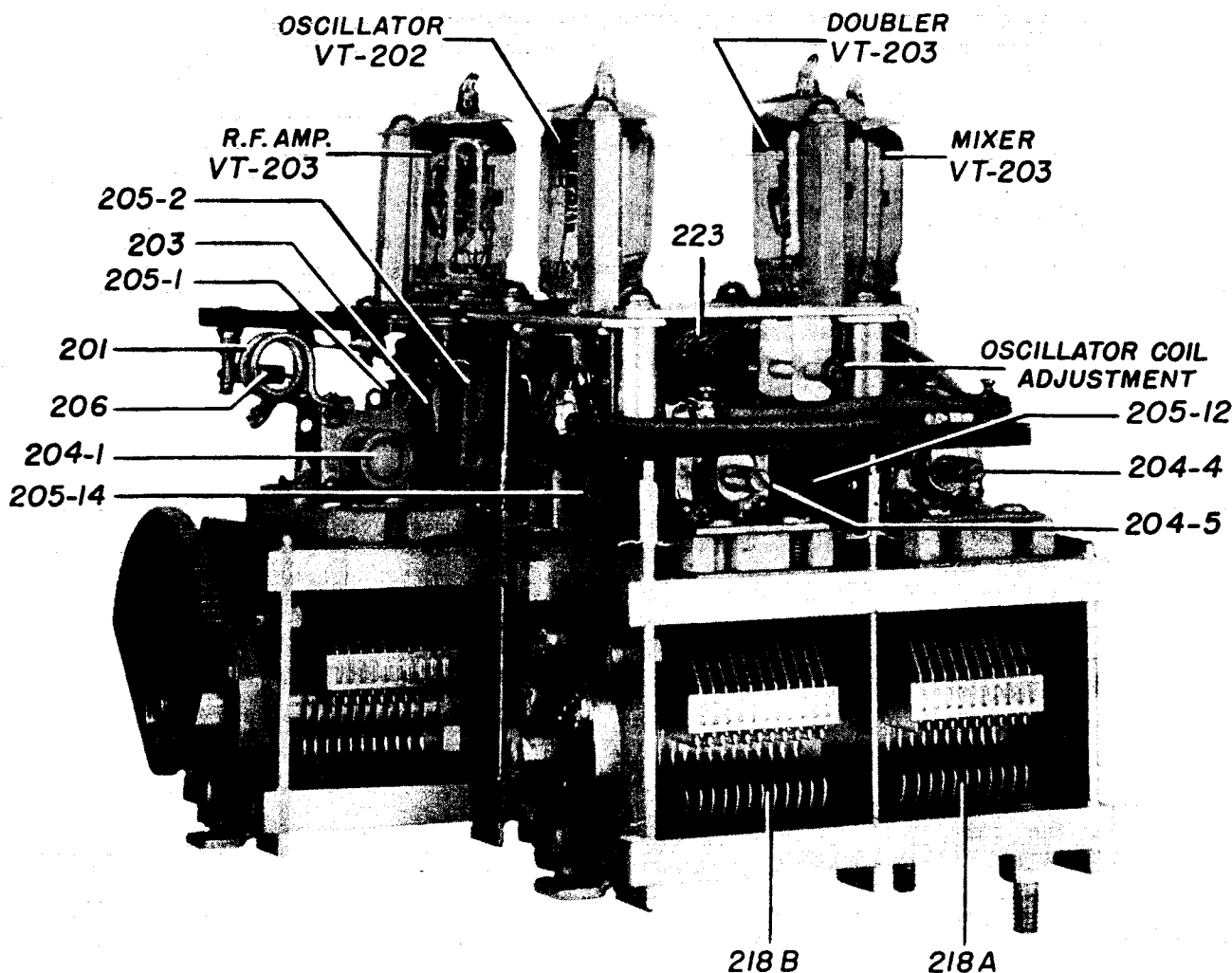

Figure 15 — Radio Receiver BC-639-A, Front Oblique, R. F. and Oscillator

(g) Resolder the four wires coming from below the chassis to the terminal strip at the left side of the radio frequency tuning gang.

(h) Align the radio frequency assembly in connection with the oscillator assembly as explained in paragraph 34d., section V.

b. TO REPLACE DUST COVER ON CHASSIS.

(1) Fasten the five screws along the *top front edge* of the dust cover *behind* the front panel.

(2) The five screws along the *bottom front edge* of the dust cover *behind* the front panel.

(3) The two screws on each edge of the rear surface of the dust cover.

(4) The three screws around the antenna terminal.

c. TO REPLACE RADIO RECEIVER BC-639-A IN STANDARD RACK MOUNTING.—Grasp the handles mounted on the front panel and slide the unit into the rack mounting from the front. Replace and fasten the six roundhead machine screws which pass through the three slots at each side of the panel.

d. POWER AND ANTENNA CONNECTIONS.—Replace the power supply cable in the socket provided for it at the rear of the chassis. Replace the 70-ohm coaxial transmission line from the antenna in the antenna socket at the rear of the unit.

28. ROUTINE INSPECTION AND OVERHAUL.

a. GENERAL.—Remove the receiver from the rack by removing the six screws holding the panel to the rack.

(1) Remove the dust cover by removing the fifteen round-head screws, including the three screws around the antenna terminal, holding it on the chassis.

(2) *BE VERY CAREFUL NOT TO BEND ANY OF THE COILS AND DO NOT TOUCH THE TRIMMER CAPACITORS.* The shape of the small coils may be distorted, as a result of alignment adjustments of the receiver. *Do not attempt to change their shape.*

(3) Inspect all nuts, bolts, and screws for tightness. Do not tighten glyptal screws or nuts unless you see that they are loose. If they are loose, remove the screws or nuts, apply glyptal, replace, and tighten.

(4) Remove loose solder, dirt, and metallic chips. Clean the equipment thoroughly and touch up scratched paint.

(5) Remove all traces of corrosion.

(6) Inspect soldered joints and wiring. If more than two strands are broken at a soldered joint, resolder the connection.

(7) Remove all plug connectors and clean if necessary.

CAUTION

While making the above inspections, do not disturb alignment adjustments or wiring unless absolutely necessary.

b. Check all tubes using Supreme Tube Tester, Model 504-A, or any tube tester which will test the type tube used in the receiver, in accordance with the instructions provided with the instrument. See that all tubes are securely mounted in their sockets. When replacement is necessary, follow the instructions given in paragraph 40, section V.

c. TUNING MECHANISM.—Remove all dirt and old grease. Lubricate gears and tuning shaft coupling as described in paragraph 30, section V.

d. TUNING CAPACITOR.—Inspect for dirt between the plates. Clean carefully with a pipe cleaner. *Be careful not to bend plates. DO NOT LUBRICATE. Do not blow out as the air hose may contain water or produce sufficient pressure to bend the plates.*

e. Test as in paragraph 31, section V, if there is any reason to think that performance is not normal.

CAUTION

DUST ON THE HIGH FREQUENCY COMPONENTS OF THIS RECEIVER MAY DECREASE THE SENSITIVITY. REMOVE THE DUST COVER ONLY WHEN ABSOLUTELY NECESSARY. PUT THE DUST COVER BACK AS SOON AS YOU CAN. BE SURE THE 15 DUST COVER SCREWS ARE ALL TIGHT AS THE ELECTRICAL SHIELDING OF THE COVER WILL BE LESSENERED IF GOOD CONTACT IS NOT MADE BETWEEN THE COVER AND THE RECEIVER CHASSIS AND PANEL.

29. INSPECTION AFTER OVERHAUL OF EQUIPMENT.

Repeat operational inspection as detailed in paragraph 25, section V, after making the routine checks or overhauling procedure listed in paragraph 28, section V.

30. LUBRICATION.

Do not lubricate the variable tuning capacitor, potentiometers, or any trimmer adjustments. Lubricate the tuning gear mechanism as follows:

a. Lubricate the assembly with Royco No. 6A or Andok "C" grease, available at the depot maintenance station.

NOTE

Lubrication should not be necessary for about one year of normal use. There will be no danger of the grease producing an effect on the tuned circuit. Take the same care when lubricating the dial drive assembly as in all other operations or maintenance procedures carried out on this receiver.

31. TROUBLE LOCATION AND REMEDY OF FAULTS.

You can find open and short circuits more easily if, instead of testing at random points, an orderly plan is followed. Using the schematic and wiring diagrams for guidance, (figs. 22, 23 and 24) test one part of a circuit at a time. Check each element in that part for open circuits and grounds by measuring the resistance from point-to-point with the voltohmmeter provided in the station. If measured values of resistance agree with the resistance chart in paragraph 33, section V, that particular part of the circuit is probably not at fault and needs no further atten-

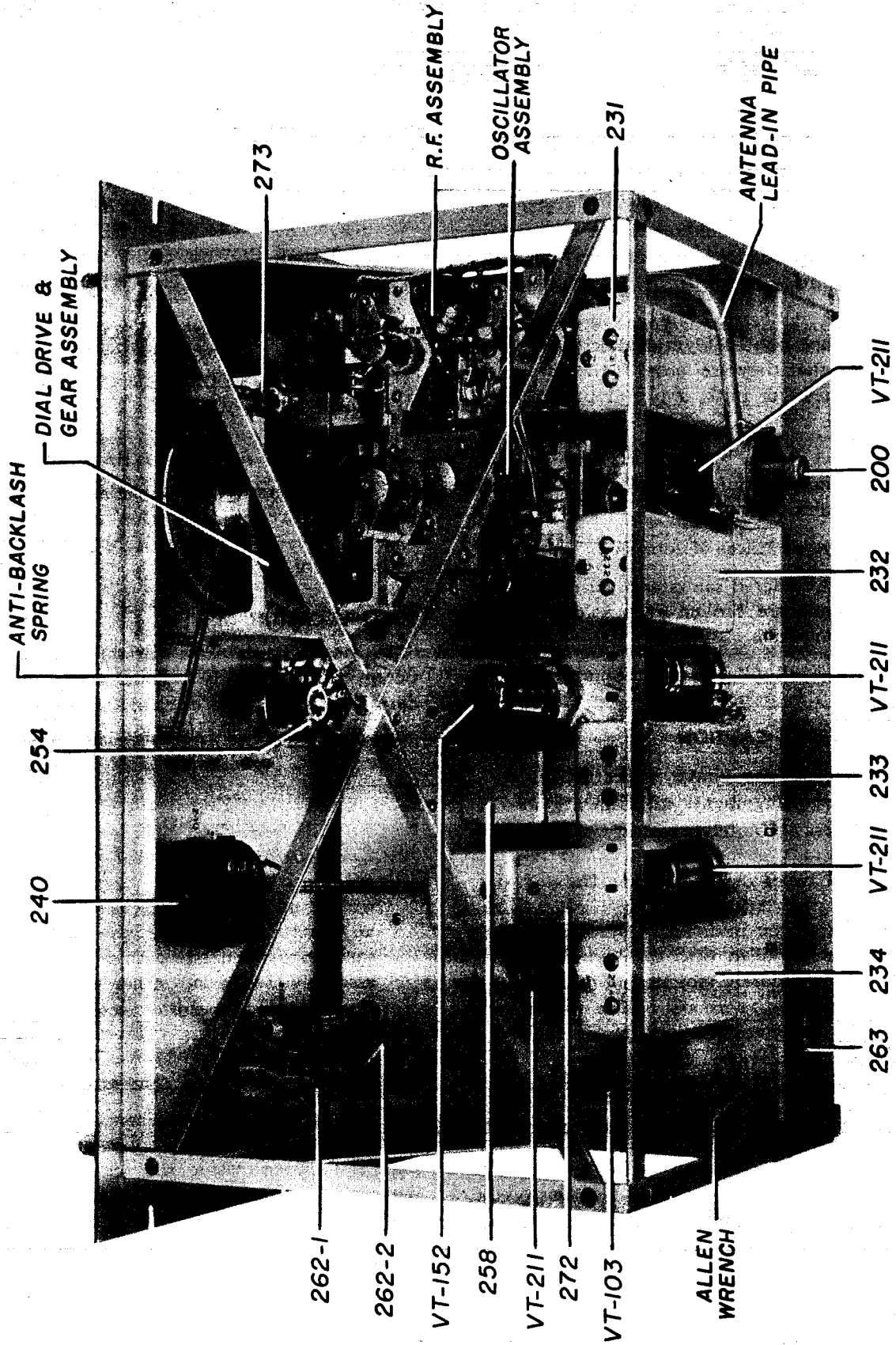

Figure 16 — Radio Receiver BC-639-A, Rear Oblique, Top View

tion. The identifying symbols of all components are given on the diagrams and their normal values can

be found by reference to the Table of Replaceable Parts, paragraph 44, section VII.

	<i>Symptom</i>	<i>Probable Cause of Trouble</i>
1.	Broad tuning.	I-f's improperly aligned. Very strong signal.
2.	Dead spot.	Improper r-f or oscillator alignment. Defective oscillator tube.
3.	Excessive hum.	Defective power supply.
4.	Noise with antenna connected but no noise with antenna disconnected.	Defective antenna transmission line. Noisy electrical equipment in station, (check fluorescent light). Gasoline engines or electrical equipment located within 500 ft. of antenna.
5.	Noise with antenna disconnected.	Loose or poorly soldered connections. Poor or corroded ground connections. Noisy or defective tubes. Leaky fixed capacitor. Defective resistor.
6.	Signal distorted or muffled.	Defective high frequency oscillator tube. Leaky capacitor 230-18. Defective audio output tube. C.W. AND MANUAL, MANUAL, A.V.C. switch at MANUAL when strong signal is being received. C.W. AND MANUAL, MANUAL, A.V.C. switch at C.W. AND MANUAL.
7.	Signal weak.	Defective tubes. Low plate voltage from power supply. Defective antenna transmission line. Improper alignment. Threshold Sensitivity not properly adjusted.
8.	Signal weak at one end of dial.	R-f improperly aligned. Defective oscillator or doubler tube.
9.	Stations not received at proper points on dial.	R-f aligned at wrong frequency. I-f aligned at wrong frequency. Capacitor gears improperly adjusted.
10.	Vacuum tubes VT-202 and VT-203 frequently need replacing.	Filament voltage too high. Excessive vibration.
11.	TUNING METER indicates 5 MA but does not dip when receiving signal.	Defective C.W. AND MANUAL, MANUAL, A.V.C. switch. Switch in MANUAL Position. Defective capacitor 215-2. Shorted capacitor 230-16.
12.	Noisy AUDIO GAIN INCREASE control.	Defective control 251. (replace).
13.	Receiver output can be heard in MONITOR jack or LINE jack but cannot be heard at terminals 11 and 12 on Jones plug.	Dirty contacts on LINE jack, 262-2. Broken connection.
14.	Impossible to hold a steady tone with C.W. AND MANUAL, MANUAL, A.V.C. switch in C.W. AND MANUAL position.	Received signal not of constant frequency. C.W. oscillator tube not warmed up. Loose connections in C.W. oscillator circuit. Varying plate voltage from the power supply.
15.	Tone very weak when C.W. AND MANUAL, MANUAL, A.V.C. switch is in C.W. AND MANUAL position.	Open capacitor 267 and 246. C.W. oscillator improperly tuned. Defective C.W. oscillator tube.

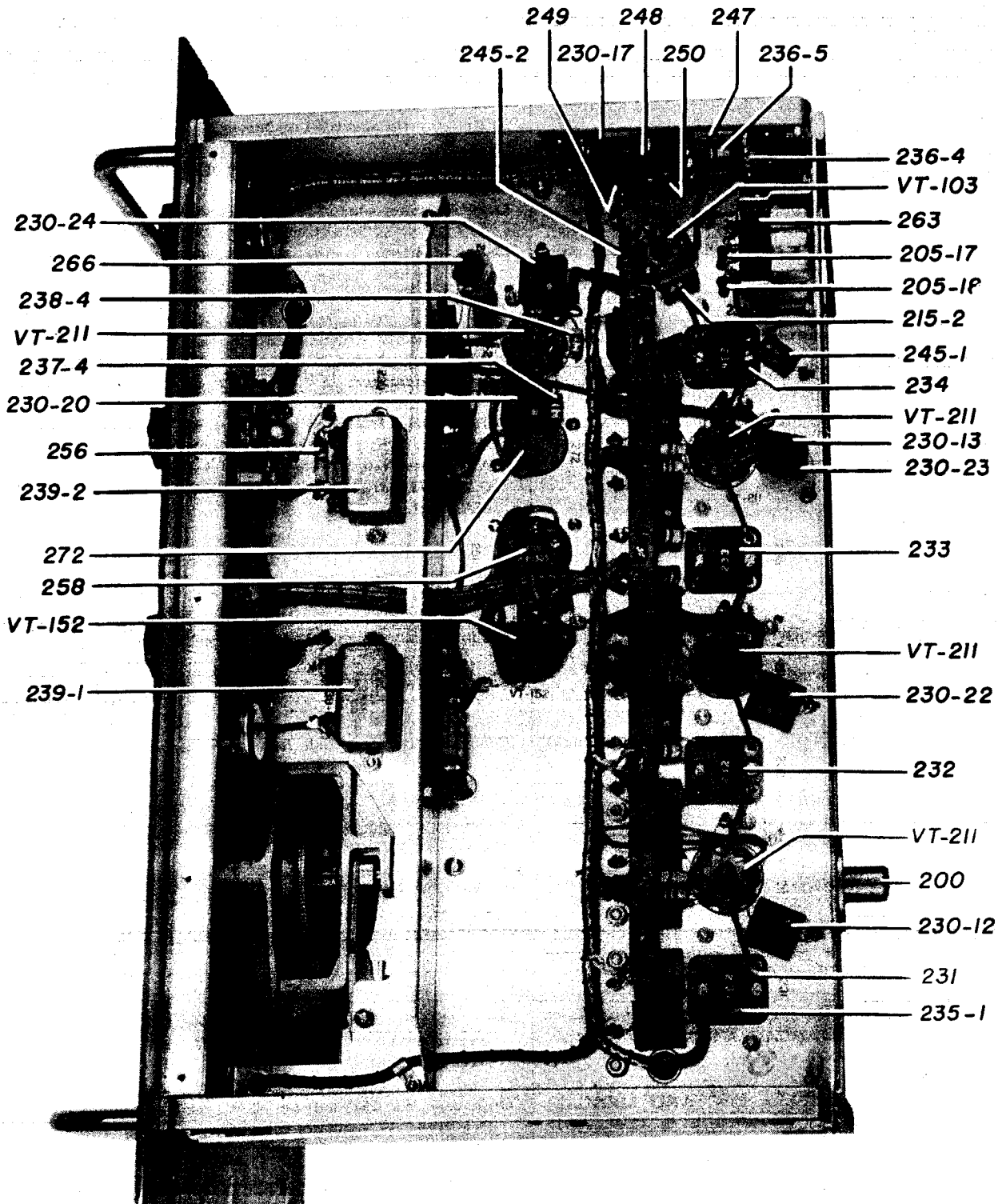

Figure 17 — Radio Receiver BC-639-A, Left Oblique, Bottom View

	<i>Symptom</i>	<i>Probable Cause of Trouble</i>
16.	Pilot lamp burns out frequently.	Excessive filament voltage. (Check this voltage as this will also shorten life of vacuum tubes.)
17.	Absolutely no output (not even noise).	Open headsets or headset cord.
18.	Normal set noise but no signal with or without antenna connected.	Defective high frequency oscillator and/or doubler.
19.	Output practically nil.	Cathode of VT-211 has a great tendency to open up.
20.	Some portion of the r.f. circuits inoperative (as determined by signal tracing).	Base of midget tubes cracked. This is usually a result of bent pins and is not easily noticed by inspection.
21.	Desired i.f. band width cannot be obtained in alignment.	Open or shorted condenser within the i.f. can. Defective i.f. tube.
22.	I.f.'s or r.f.'s won't align.	Signal generator set to wrong frequency.
23.	B+ voltage too high, poor regulation.	Bleeder resistor in RA-42-A,-B open. Usually a result of leaving the power supply turned on without a load connected.

The following tables list the average signal input needed at the grid of each of the amplifier tubes to produce a standard output of 10 milliwatts (2.45 volts) into a 600-ohm load. In comparing these measurements, connect the signal generator (Ferris 18B, 18C, 18D) or any signal generator which has a low impedance output and which can be accurately set to 11930 and 12070 kilocycles output directly to grid and ground, with the "hot" side to grid and the GND. side to the receiver chassis. *It is not necessary to break the normal grid connection to the tubes.*

For intermediate frequency measurements, use a signal of 12 mc modulated 30 per cent at 1000 cps. Keep the direct current supply voltage as close as you can to 210v for a 60 ma load, while making these measurements. Set the controls as follows:

- a. C.W. AND MANUAL—MANUAL—A.V.C. at MANUAL.
- b. ATTENUATION switch at 0 DB.
- c. AUDIO GAIN INCREASE control at maximum clockwise position (to the right).
- d. THRESHOLD SENSITIVITY control for 5 ma meter reading. See paragraph 34e, section V.
- e. R.F. GAIN INCREASE control set to maximum. The control remains set at this position when the sensitivity is measured at other grids.

NOTE

Due to the audio frequency response characteristic, the input for 10mw

output will be about twice the values given in the following table if 400 cps modulation is used.

<i>Tube</i>	<i>Frequency</i>	<i>Input in Microvolts for 10 mw Output (2.45 volts across a 600 ohm load)</i>
Mixer VT-203	12 mc	Less than 15
1st i-f VT-211	12 mc	35-70
2nd i-f VT-211	12 mc	500-1000
3rd i-f VT-211	12 mc	8000-16,000

By comparing the receiver performance with this data, the location of operational faults will be greatly facilitated. Check the stages in reverse order beginning with the last audio stage up to the radio frequency stages.

32. VOLTAGE MEASUREMENTS.

The voltages given below were taken by measuring from the tube socket terminal to ground (chassis). Rectifier RA-42-A (or Rectifier RA-42-B) supplies 210v direct current and 6.3v alternating current to the receiver. Measurements were made with both a voltmeter of 1000-ohms-per-volt sensitivity using

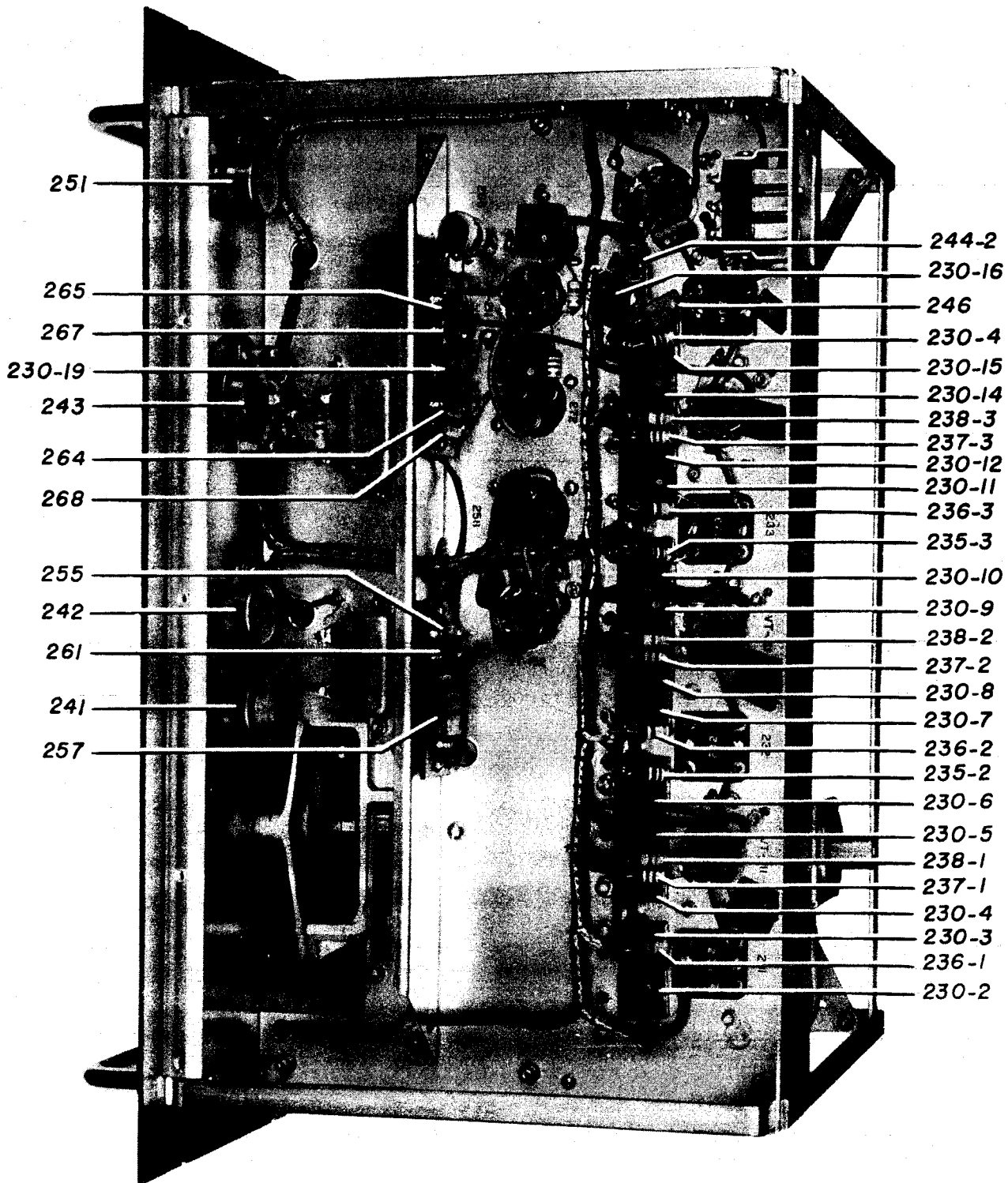

Figure 18 — Radio Receiver BC-639-A, Rear Oblique, Bottom View

the 250v scale except where otherwise stated, and an RCA VoltOhmyst, Jr. using a range which gives about two-thirds scale deflection for the value

shown. The panel control settings are the same as those specified for resistance measurements in paragraph 33, section V. See tables.

TABLE OF VOLTAGE MEASUREMENTS OF TUBES USING AN RCA VOLTOHMYST, JUNIOR.

Tube	Function	Tube Socket Terminals							
		1	2	3	4	5	6	7	8
VT-203	R-F Amplifier	0	2.7	Gnd	<u>6.3</u>	205	93	2.7	—
VT-203	Mixer	0	2.4	Gnd	<u>6.3</u>	208	53	2.4	—
VT-203	Doubler	0	4.1	Gnd	<u>6.3</u>	190	95	4.1	—
VT-202	Oscillator	180	Gnd	<u>6.3</u>	Gnd	180	-5.8*	0	—
VT-211	1st I-F Amp.	Gnd	<u>6.3</u>	2.6	0	2.6	125	Gnd	205
VT-211	2nd I-F Amp.	Gnd	<u>6.3</u>	2.6	0	2.6	125	Gnd	205
VT-211	3rd I-F Amp.	Gnd	<u>6.3</u>	2.6	0	2.6	125	Gnd	205
VT-103	Det., 1st Audio, AVC	Gnd	6	10.0	9.5	0	145	<u>6.3</u>	Gnd
VT-152	2nd Audio	NC	<u>6.3</u>	205	210	0	NC	Gnd	19
VT-211	CW Osc.	Gnd	<u>6.3</u>	Gnd	-2.7*	Gnd	122	Gnd	185

*Measurement made while tube is oscillating. Underlined figures indicate a-c voltage if Rectifier RA-42-A is used.

TABLE OF VOLTAGE MEASUREMENTS USING A 1000-OHMS-PER-VOLT VOLTMETER.

Tube	Function	Tube Socket Terminals							
		1	2	3	4	5	6	7	8
VT-203	R-F Amplifier	0	2.7†	Gnd	<u>6.3†</u>	200	93	2.7†	—
VT-203	Mixer	0	2.4†	Gnd	<u>6.3†</u>	205	45	2.4†	—
VT-203	Doubler	0	4.1†	Gnd	<u>6.3†</u>	180	95	4.1†	—
VT-202	Oscillator	140	Gnd	<u>6.3†</u>	Gnd	150	0*	0	—
VT-211	1st I-F Amp.	Gnd	<u>6.3†</u>	2.5†	0	2.5†	125	Gnd	205
VT-211	2nd I-F Amp.	Gnd	<u>6.3†</u>	2.5†	0	2.5†	125	Gnd	205
VT-211	3rd I-F Amp.	Gnd	<u>6.3†</u>	2.5†	0	2.5†	125	Gnd	205
VT-103	Det., 1st Audio, AVC	Gnd	0	5†	0.5†	0	103	<u>6.3†</u>	Gnd
VT-152	2nd Audio	NC	<u>6.3†</u>	205	210	0	NC	Gnd	20†
VT-211	CW Osc.	Gnd	<u>6.3†</u>	Gnd	0.2†	Gnd	90	Gnd	185

*High frequency oscillator grid connected to ground.

†Measured on 10v scale 1000 ohm-per-volt meter.

‡Measured on 50v scale 1000 ohm-per-volt meter.

Underlined figures indicate a-c voltage if Rectifier RA-42-A is used.

33. TYPICAL VACUUM TUBE-SOCKET RESISTANCE.

a. The values in the tables were taken from the tube socket terminal to ground (chassis) with an RCA VoltOhmyst Jr. The power supply and antenna plugs were disconnected. All tubes were in their

sockets, *except for the values so designated as having been taken with the tube removed.* The controls on the front panel were set as follows:

(1) R.F. GAIN INCREASE control at maximum.

(2) AUDIO GAIN INCREASE control at maximum.

(3) ATTENUATION switch to 0 DB.

(4) C.W. AND MANUAL—MANUAL A.V.C. switch at C.W. AND MANUAL.

(5) THRESHOLD SENSITIVITY control for 5 ma meter reading.

b. TABLE OF RESISTANCE MEASUREMENTS (OHMS).

Tube	Function	Tube Socket Terminals							
		1	2	3	4	5	6	7	8
VT-203	R-F Amplifier	660,000	330*	0	0.4	160,000	120,000	330	—
VT-203	Mixer	1.8 meg	1000*	0	0.4	160,000	430,000	1000	—
VT-203	Doubler	27,000	560*	0	0.4	164,000	215,000	560	—
VT-202	Oscillator	164,000*	0	0.4	0	164,000	47,000	0*	—
VT-211	1st I-F Amp	0	0.4	*200-300†	100,000	200-300†	206,000	0	160,000
VT-211	2nd I-F Amp.	0	0.4	*200-300†	100,000	200-300†	206,000	0	160,000
VT-211	3rd I-F Amp.	0	0.4	*200-300†	100,000	200-300†	206,000	0	160,000
VT-103	Det., 1st Audio, AVC	0	1.0 meg	20,000	220,000	500,000	293,000	0.4	0
VT-152	2nd Audio	NC	0.4	160,000	160,000	330,000	NC	0	1500
VT-211	CW Osc.	0	0.4	0	47,000	0	206,000	0	164,000

*Resistance is infinity when tube is not in its socket.

†Resistance value will vary with the setting of the THRESHOLD SENSITIVITY control.

c. Due to the difficulty in taking measurements on the r-f tubes (VT-202 and VT-203), the following

values were obtained with the tube removed from its socket.

TABLE OF RESISTANCE MEASUREMENTS (OHMS).

Tube	Function	Tube Socket Terminals						
		1	2	3	4	5	6	7
VT-203	R-F Amplifier	660,000	Infinity	0	0.4	160,000	120,000	330
VT-203	Mixer	1.8 meg	Infinity	0	0.4	160,000	430,000	1000
VT-203	Doubler	27,000	Infinity	0	0.4	164,000	215,000	560
VT-202	Oscillator	Infinity	0	0.4	0	164,000	47,000	Infinity

d. The following measurements were taken from Jones plug terminals to ground:

Terminal No.....	7	8	9	10	11	12
Resistance (ohms)...	0	0.4	0	160,000	4800	4800

34. ALIGNMENT USING SIGNAL GENERATOR.

a. INTERMEDIATE FREQUENCY AMPLIFIER ALIGNMENT.

(1) Connect the signal generator (Ferris 18B, 18C, 18D or 16C or any signal generator which has a low impedance output and which can be accurately set to 11930 and 12070 kc) output lead directly

to the mixer tube (VT-203) control grid (front lug with a resistor and capacitor attached to it), connect the lead shield to the capacitor frame, and connect a grounding clip at about the center of the generator output lead and connect this clip to the chassis. Keep all connections from the generator to the receiver and ground as short as possible.

(2) Set the output load, and the controls as outlined in paragraph 37, section V. Turn the **THRESHOLD SENSITIVITY** control all the way to the right. Turn the power source ON and allow two or three minutes for the tubes to warm up.

(3) With the generator emitting a 5 to 10 microvolt signal at 12000 kc, modulate the signal 30% at 1000 cycles, and set the generator output high enough to hear the signal. Adjust the iron core at the tops of intermediate frequency assemblies 234 and 233 (starting from right to left with the front panel facing you) for maximum deflection of the output meter. *These transformers are critically coupled and should be accurately peaked.* The screw at the extreme right controls tuning of secondary circuit of the last i.f. transformer.

(4) Set the signal generator to 11930 kc, with modulation on as above, and adjust the iron core in the primary of intermediate frequency assemblies 232 and 231 (starting from left to right with the front panel facing you) for maximum deflection of the output meter. The primary IF coils 229-1 and 229-3 are on the right hand side at the top of the IF assemblies with the front panel facing you (see fig. 22, section VII, drawings).

(5) Set the signal generator to 12070 kc and proceed as outlined in sub-paragraph 4 above to adjust the iron core in the secondary of intermediate frequency assemblies 232 and 231. The secondary IF coils 229-2 and 229-4 are located on the left hand side at the top of the IF assemblies and are also shown (see fig. 22, section VII, drawings). Loading or detuning of secondaries while aligning primaries, or of primaries while aligning secondaries may be necessary. The signal output is then noted as the signal generator is tuned between 11930 and 12070 kc's, and if the variation is too great, the alignment procedure is repeated until the proper flat-topping results, with a rapid falling off of output indicated when the signal generator is set to a frequency beyond the given limits. If an oscilloscope and a sweep signal generator is available the visual method can be used to insure the proper intermediate frequency amplifier characteristics required for broad band alignment.

(6) Adjust the signal generator output and the **R.F. GAIN INCREASE** control for 10 to 1 signal to noise ratio. [See paragraph 37b(6), section V].

With this setting of the controls and generator, repeat steps (3) to (6) above.

When properly aligned, the intermediate frequency transformers should have a sensitivity at 10 to 1 signal-to-noise ratio of better than 15 microvolts

(usually around 10 microvolts), and the output meter should show about the same rise and fall on both sides of 12 mc. as the generator is tuned from one side of resonance to the other.

Note

While it is desirable to obtain 12 mc for the center of the intermediate frequency band, no difficulty will be experienced in operation of the receiver if a deviation occurs up to 1/2 mc; as long as all intermediate frequency transformers and the beat frequency oscillator are aligned relative to this new center frequency. It is important that the first and second intermediate frequency transformers are aligned at 70 kc above and 70 kc below the center frequency. (70 kc is represented by approximately 1.4 scale divisions on a Ferris 18D signal generator). NOTE: Always approach the desired signal generator dial setting from a lower dial setting, even when resetting from a higher dial reading. This minimizes setting inaccuracies caused by the mechanical back-lash.

b. BEAT FREQUENCY OSCILLATOR ALIGNMENT.—After you have completed the intermediate frequency alignment, the beat frequency oscillator alignment should follow, and no changes should be made in the set-up. Use the same set-up as used for intermediate frequency.

(1) Set the **C.W. AND MANUAL, MANUAL, A.V.C.** switch to **C.W. AND MANUAL**. Set the **C.W. TONE CONTROL** pointer to the index line at the center of the arrowed line. With the pointer set at the index line, the *red* line on the shaft attached to the rear coupler should be up.

(2) Set the signal generator to 12 mc. and turn the modulation OFF. Set multiplier and attenuator for maximum radio frequency output.

(3) Insert a screwdriver through the opening in the beat frequency oscillator assembly (272) to the left of the C.W. oscillator Tube VT-211. Turn this screw until a zero-beat is obtained. Without changing any setting, turn the **C.W. TONE CONTROL** to the right or left to give about a 1000-cycle pitch, or set the control for maximum audio output.

(4) With a screwdriver, turn the C.W. oscillator plate coil iron core screw, on the chassis to the right and in front of the VT-211 tube, until you get maximum output. Turn the screw one turn clockwise (*to right*) past this maximum point. This proves the overall stability of the receiver in the C.W. position. The oscillator portion operates at 6 mega-

cycles and is variable. The plate circuit of the oscillator tube is tuned to 12 megacycles. The oscillator tube therefore operates as both an oscillator and a frequency doubler.

c. GEAR AND TUNING CAPACITOR ALIGNMENT.

(1) The quadrant gear in the gear drive assembly should be tightened to its shaft in such a position that it does not touch the casting when the tuning knob is moved from stop to stop.

(2) The tuning knob should be rotated counterclockwise (*to the left*) and held against the stop. The dial should be turned until the line marked STOP is at the index on the dial window. Tighten the two set screws in the dial hub.

(3) The two quadrant gears (one mounted on the drive and the other on the three gang capacitor assembly) should be meshed so that when the tuning knob is in the extreme counterclockwise position, the top edges of these gears are about parallel to the chassis.

(4) Turn the tuning knob clockwise until the line on the dial marked ALIGN is at the index on the window. The dial is held in this position until both capacitors (two gang and three gang) are set full mesh. To set the capacitors, turn them with respect to their quadrant gear. For the three gang, you can do this by loosening the two Allen set screws in the hub of the quadrant gear. For the two gang capacitor, the set screws in the coupling can be loosened. Tighten all set screws and check to see that both capacitors are in full mesh when the dial is set at ALIGN. No other gear adjustment is needed.

d. RADIO FREQUENCY AND HIGH FREQUENCY OSCILLATOR ALIGNMENT.—

CAUTION: The alignment of the tuned radio frequency and high-frequency oscillator circuits are the most difficult operations to perform in the maintenance of the receiver. Only skilled, trained personnel having the necessary tools should attempt this alignment. It is emphasized again that indiscriminate adjustments or carelessness may seriously damage the receiver.

The quadrant gears must be properly placed and set, and the capacitors set at a predetermined point before proceeding to align the radio frequency portion of the receiver. Check these settings carefully as follows:

(1) Turn the dial mechanism to ALIGN.

(2) The rotor (moving) plates of the three gang capacitor must be flush with the stator (fixed) plates at the left side of the capacitor, looking at it from the front of the receiver. If resetting is required, loosen the quadrant gear where it is attached to the three gang shaft by loosening the two set screws and moving the capacitor plates until they are lined up. An Allen wrench is attached near the right rear top corner of the chassis for this purpose. If any set screw is loosened put a small amount of glyptal on the threads of the screw before retightening it.

(3) The rotor plates of the two gang capacitor must be flush with the stator plates at the right side of the capacitor, looking at it from the front of the receiver. If resetting is required, loosen the set screws on the front of the coupler, with the Allen wrench, reset the capacitor, put a small amount of glyptal on the screw threads, and retighten the set screw.

NOTE

It may be impossible to reset the capacitor plates so that they are flush at the edges. The set screw will make a groove in the capacitor shaft when it is tightened and unless it is possible to reset the capacitor so that the setscrew is moved at least one-half the diameter of the groove, it is best to leave the capacitor at the old setting provided the difference is not more than one sixty-fourth of an inch from the flush point. If you are off a little from the flush setting it will not seriously affect the final overall performance of the receiver.

(4) The tools required to make the radio frequency alignment correctly are:

An insulated screwdriver for trimmer adjustments.

A pair of bakelite or fibre tools about $\frac{1}{4} \times \frac{1}{2}$ inch and about 4 to 6 inches long with a tapered point at one end to adjust the inductances.

A pair of long-nose pliers with insulated jaws or the jaws cut off and bakelite jaws added.

(5) Connect the terminated line from the signal generator to the antenna plug of the receiver, connect the receiver to the power source, and set the controls as covered in paragraph 37b, section V.

(6) Turn the THRESHOLD SENSITIVITY control full ON, (to the right). Turn the R.F. GAIN INCREASE control full ON.

Revised 24 December 1951

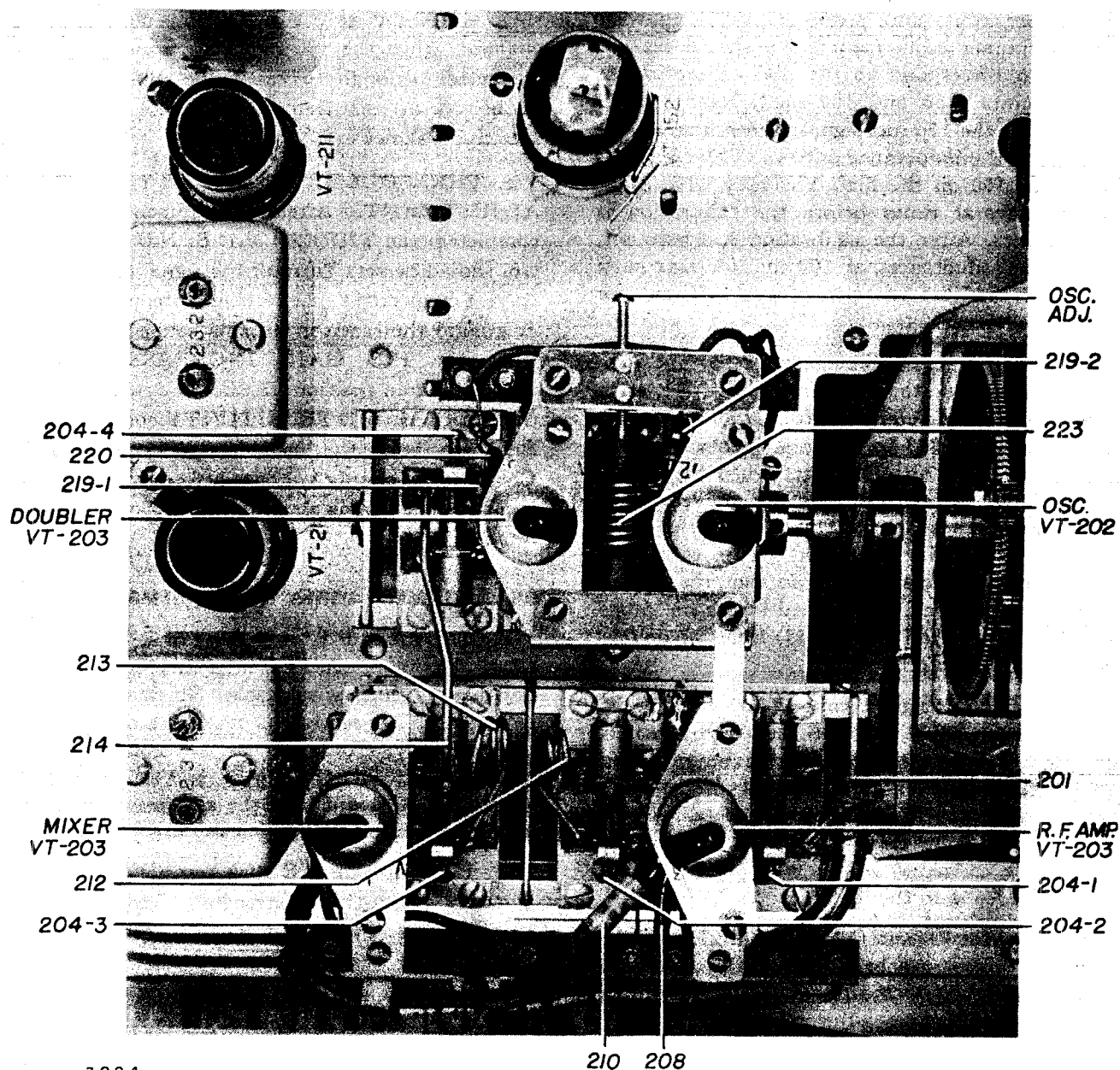

3024

Figure 19 — Radio Receiver BC-639-A, Top View, R. F. and Oscillator Assembly

(7) Set the signal generator to 156 mc, modulated 30% at 1000 cycles.

It will usually be necessary to use a high output from the generator to start, and reduce it, and the R.F. GAIN INCREASE control, as the various stages are brought into resonance.

Set the receiver dial to 156 mc.

Adjust the oscillator trimmer (204-5) (lower screw on the front section of the two gang capacitor) until the signal is heard in the headset. (See fig. 15.)

Adjust all other high frequency trimmers (reference nos. 204-4, 204-1, 204-2, and 204-3), for maximum deflection of the output meter. (See figs. 15 and 19.)

(8) Set the signal generator and receiver to 100 mc. and adjust the inductance of the oscillator coil (top screw on the front section of the 2-gang condenser) until the signal is heard. (See figure 19.) Adjust the inductances of all high frequency coils by squeezing them together or spreading them apart, using the insulated tools, for maximum meter deflection of the output meter.

Before continuing with the high-frequency coil and trimmer adjustments, you should set the oscillator to correspond to the dial calibration at the end points (156 and 100 mc.). Readjust the trimmer until the 156 mc. signal comes in at 156 on the dial, and the inductance until the 100 mc. signal comes in at 100 on the dial. You may have to go over this several times before the calibration is accurately set. After the calibration has been set, readjust the inductances at 100 mc. for maximum output and readjust the trimmers at 156 mc. for maximum output.

(9) Set the signal generator to 130 mc. and tune the signal in on the receiver. Adjust the spacing between the r-f plate coil Ref. No. 212 and the mixer grid coil Ref. No. 213 to about $\frac{1}{4}$ inch apart. (See fig. 19.) The exact spacing is set when the output reading decreases as the coils are moved either together or further apart. This adjustment is for the "mutual" setting only and serves to set the coils in relation to each other so that the circuits will track as the receiver is tuned across the range. Place the hair-pin coil (see fig. 19) from the doubler stage for maximum output.

(10) After setting the coils at 130 mc. readjust the inductance of the coils at 100 mc. by moving the outside turns of the coil for maximum output holding the inside turn so that it does not move in respect to the other coil. Adjust the hairpin coil from the doubler for maximum output by changing the effective diameter of the loop or the spacing between the leads to the loop.

(11) Repeat (8) and (10) above until no further increase in output can be obtained. *Do not touch the oscillator adjustment after it has been set in (8).* Make the final adjustment at 156 mc. by means of the trimmers.

(12) Set the **THRESHOLD SENSITIVITY** control so the meter will read 5 ma. with the R.F. **GAIN INCREASE** control full ON.

(13) Make a series of sensitivity measurements every 10 mc. beginning at 100 mc. The microvolt input at 10 to 1 signal-to-noise ratio should be less than 5 microvolts at any point, and measurements of input voltage for the same output voltage made 10 mc. apart should not ordinarily vary more than 1 microvolt. If the sensitivity varies more than 1 microvolt from one 10 mc. measurement to the next (for example between 100 to 110 mc.) check the placing of the hairpin coil from the doubler

stage at 130 mc. as the relationship may have been changed, when the 100 mc. inductance adjustment was made, enough to cause the mutual coupling to be off at the frequencies where the lowered sensitivity shows up.

e. **THRESHOLD SENSITIVITY CONTROL ADJUSTMENT.**—After all alignments have been completed, the **THRESHOLD SENSITIVITY** control should be set. Turn off the signal generator but leave it connected to the receiver antenna connection, or ground the receiver antenna connection directly. Turn the **R.F. GAIN INCREASE** control to maximum gain position. Reduce the gain by turning the **THRESHOLD SENSITIVITY** control counterclockwise until the meter reads 5 milliamperes. Check power supply voltages before this adjustment is made. The tuning should now read approximately 5 ma.

35. ALIGNMENT USING TEST EQUIPMENT IE-19-A.

Signal Generator I-130-A (part of Test Equipment IE-19-A) can be used to align the radio frequency and high-frequency oscillator. No dummy antenna is required. The receiver is connected directly to the generator by means of the low-impedance, concentric Cord CD-477 which is part of the test equipment. Proceed with the alignment as in paragraph 34, section V.

Test Equipment IE-19-A cannot be used to properly align the intermediate frequency transformers and the beat-frequency oscillator. This alignment is best done with a Ferris 16C signal generator, but satisfactory results can be obtained with a Ferris 18B, 18C, or 18D or any signal generator which has a low impedance output and which can be accurately set to 11930 and 12070 kc (see paragraph 34, section V).

36. ALIGNMENT USING FREQUENCY METER BC-638-A.

Frequency Meter BC-638-A may be used to align the radio-frequency and high-frequency oscillator. The frequency-meter antenna must be left in place so that the signal can be transmitted to the receiver. The receiver antenna should be in place.

Proceed with alignment as in paragraph 34, section V. Use the crystals which provide signals near the specified alignment frequencies.

The intermediate frequency transformers and beat-frequency oscillator cannot be properly aligned with Frequency Meter BC-638-A.

37. OVERALL PERFORMANCE TESTS.

a. **GENERAL.**—If at any time the operation of Radio Receiver BC-639-A is questionable, measure its performance using the following procedure.

Make all repairs or adjustments, and check to insure that the adjustments have been properly made. These measurements should conform to the normal performance characteristics given in paragraph 37b.

b. STANDARD TEST CONDITIONS.

(1) **INPUT POWER VOLTAGE.**—200 to 250v a-c when used with Rectifier RA-42-A or Rectifier RA-42-B with supply voltage control set to proper input voltage.

5.5v to 6.3v d-c to dynamotor when used with Dynamotor Unit PE-100-A.

NOTE

When using Dynamotor Unit PE-100-A power supply, the filament supply voltage is slightly lower than that of Rectifier RA-42-A (or Rectifier RA-42-B). The plate voltage should remain about the same. The input voltage to Rectifier RA-42-A (or Rectifier RA-42-B) may be 100-125 volts alternating current provided the power transformer is properly connected and SUPPLY VOLTAGE CONTROL switch is set to the correct value. See *Instruction Book for Operation and Maintenance of Rectifier RA-42-A and Rectifier RA-42-B.*

(2) **WARM-UP PERIOD.**—Five minutes unless otherwise stated.

(3) **ARTIFICIAL ANTENNA.**—Electrical equivalent of 70-ohm line. (*If a Ferris Model 18D signal generator, which has an output impedance of approximately 14 ohms is used, a 50-ohm ± 5 per cent, non-inductive resistor is placed in series with the "hot" side of generator output.*)

(4) **STANDARD INPUT SIGNAL.**—Obtained from Ferris Model 18B, 18C, 18D or 16C or any signal generator which has a low impedance output and which can be accurately set to 11930 and 12070 kc. modulated 30 per cent at 1000 cps.

(5) **OUTPUT LOAD.**—600 ohms (non-inductive).

(6) **SIGNAL-TO-NOISE RATIO.**—The standard signal-to-noise ratio is 10 to 1 for 10 mw output. To obtain 10 to 1 signal-to-noise ratio the R.F. GAIN INCREASE control and signal input voltage are adjusted at the same time until the power output, with modulation on (signal modulated by 1000 cycles), is ten times the power output with carrier modulation OFF at 30% only. Since these sensitivity measurements are based on 10:1 signal-to-noise ratio with 10 mw output, there should be an output of 10 mw (2.45 volts across a 600-ohm resistor load) with modulated carrier and 1 mw (.775 volts across a 600-ohm resistor load) with unmodulated carrier. *On some generators, the carrier frequency may be shifted slightly by modulation, and it may be necessary to retune receiver when modulation is removed to come back on carrier or "noise".*

(7) **R.F. GAIN INCREASE CONTROL.**—Set at maximum, unless noise level reduction is necessary to obtain a 10:1 signal-to-noise ratio.

(8) **AUDIO GAIN INCREASE CONTROL.**—Set at maximum unless otherwise specified.

(9) **C.W. AND MANUAL—MANUAL—A.V.C. SWITCH.**—Set at MANUAL unless otherwise specified.

(10) **ATTENUATION SWITCH.**—Set at 0 DB.

(11) **DUST COVER OF RECEIVER.**—The dust cover shall be replaced for measurements made on overall performance; with signal fed into antenna post of receiver.

(12) **ALIGNMENT OF RECEIVER.**—Align all circuits of the receiver properly in accordance with the alignment procedure given in paragraph 34.

c. **METHODS OF MEASUREMENT.**—To make performance tests, each measurement should be made as described in the text below.

(1) INTERMEDIATE FREQUENCY SENSITIVITY AND SELECTIVITY.

(a) Connect the signal generator directly to the grid of the mixer tube. Modulate a 12 mc. carrier to 30 per cent at 1000 cps.

(b) Connect the output of the receiver to a standard non-inductive load of 600 ohms.

(c) Adjust the output of the signal generator and adjust the R.F. GAIN INCREASE control for

a 10 to 1 signal-to-noise ratio with 10 mw output. Record this sensitivity. The signal input should be less than 15 μ v.

(d) Increase the input 2 times, or 6 db, and adjust the signal generator above and below resonance to the frequencies required to produce 10 mw output, leaving the R.F. GAIN INCREASE control unchanged. Compute the total band-width.

(e) Repeat step (d) above for input voltage ratios of 100 times (40 db) and 1000 times (60 db.) The results should conform as follows:

Ratio	Limit
X2	More than 130 kc
X100	Less than 350 kc
X1000	Less than 450 kc

Accurate values cannot be obtained in this test with a Ferris Signal Generator Model 18C or 18D. Model 16C is recommended for accurate measurements. However, the band-width will conform with values in above table if receiver is properly aligned.

(2) FIDELITY.

(a) Connect the signal generator directly to grid of the mixer tube.

(b) Connect an audio-frequency generator to the external modulation terminals of the signal generator so that signal of latter may be modulated 30 per cent at any audio frequency from 200 to 5,000 cps.

(c) With a 12-mc carrier modulated 30 per cent at 1000 cps, adjust the output of the signal generator and adjust the R.F. GAIN INCREASE control for 10 to 1 signal-to-noise ratio with 10 mw output. This is the normal intermediate frequency sensitivity.

(d) Reduce gain for 1/10 normal sensitivity; that is, increase signal input voltage to 10 times the normal sensitivity value and decrease the R.F. GAIN INCREASE control to maintain 10 mw output. Increase input to give 50 mw output.

(e) The audio response should be flat (+2 -6db) from 600 to 2500 cps inclusive. The signal should be attenuated at least 10 db at 200 cps and 5000 cps, referred to 50 mw at 1000 cps as the reference level.

(3) OUTPUT REGULATION.

(a) Connect the signal generator directly to the grid of the mixer tube. Modulate a 12-mc carrier 30 per cent at 1000 cps.

(b) Adjust the signal generator output and the R.F. GAIN INCREASE control for 10 to 1 signal-to-noise ratio at 10 mw output. This is the normal intermediate frequency sensitivity.

(c) Increase the signal input voltage to 10 times the normal sensitivity value and decrease the R.F. GAIN INCREASE control to maintain 10 mw output. Increase the signal input to produce 50 mw output.

(d) Leaving above conditions unchanged, vary the load impedance between 200 ohms and 20,000 ohms, and record the output power level in db referred to 50 mw into 600 ohms load at 0 DB.

(e) The output regulation is such that the output will not change more than +6 db to -6 db with an output impedance change of from 200 ohms to 20,000 ohms at 1000 cps, referred to the 600-ohm reference level.

(4) NORMAL RADIO FREQUENCY SENSITIVITY.

(a) Connect the signal generator to the antenna of the receiver through the proper dummy antenna [see Paragraph 37b (3)]. Modulate the carrier 30 per cent at 1000 cps. Connect the output of the receiver to a 600-ohm non-inductive load.

(b) At each test frequency between 100 and 156 mc adjust the signal generator output and R.F. GAIN INCREASE control for 10 to 1 signal-to-noise ratio with 10 mw total output. Record signal-to-noise ratio if 10 to 1 cannot be obtained.

(c) Between frequencies of 100 mc and 156 mc, the sensitivity should be better than 5 μ v for 10 to 1 signal-to-noise ratio, 10 mw output.

(5) INPUT AS COMPARED WITH OUTPUT.—At no point up to 100,000 μ v input should the output drop below 500 mw for 1000 cps modulation. This requirement should also be met on C.W. operation. On A.V.C. the output should increase with increasing input up to 1,000 μ v. *It may be necessary to retune the receiver for the different inputs because the signal generator is sometimes detuned by its attenuator.*

(6) IMAGE FREQUENCY REJECTION.

(a) Connect the signal generator to the antenna of the receiver through the proper dummy antenna [see Paragraph 37b (3)]. Modulate the carrier 30 per cent at 1000 cps. Connect output of receiver to 600-ohm non-inductive load.

(b) At each test frequency between 100 to 156 mc, adjust the signal generator output and R.F.

GAIN INCREASE control for 10 to 1 signal-to-noise ratio with 10 mw total output. Record signal-to-noise ratio if 10 to 1 cannot be obtained.

(c) Adjust the signal generator frequency to the image frequency (signal frequency less twice the intermediate frequency) and record the input in μv necessary to produce 10 mw output.

(d) The image rejection ratio is the ratio of the input at the image frequency to the input at the signal frequency required to produce a 10 mw output.

(e) For test frequencies between 100 and 156 mc, the ratio should be greater than 3000 to 1 or approximately 70 db.

(7) INTERMEDIATE FREQUENCY REJECTION.

(a) Connect the signal generator to the antenna of the receiver through the proper dummy antenna [see Paragraph 37b (3)]. Modulate the carrier 30 per cent at 1000 cps. Connect the output circuit of the receiver to a 600-ohm non-inductive load.

(b) At each test frequency between 100 and 156 mc, adjust the signal generator output and R.F. **GAIN INCREASE** control for 10 to 1 signal-to-noise ratio with 10 mw total output. Record signal-to-noise ratio if 10 to 1 cannot be obtained.

(c) Change input frequency to intermediate frequency (12mc) and record input in μv necessary to produce 10 mw output.

(d) The intermediate frequency rejection ratio is the ratio of the input at the intermediate frequency to the input at the signal frequency to give 10 mw output. **DO NOT SELECT TEST FREQUENCIES WHICH ARE AT OR NEAR HARMONICS OF INTERMEDIATE FREQUENCY.**

(e) For test frequencies between 100 and 156 mc, the ratio should be greater than 20,000 to 1 or about 86 db.

(8) UNDESIRED RESPONSES.

(a) Connect the signal generator to the antenna of the receiver through the proper dummy antenna [see Paragraph 37b (3)]. Modulate the carrier 30 per cent at 1000 cps. Connect the output of the receiver to a 600-ohm non-inductive load.

(b) At each test frequency between 100 and 156 mc, adjust the signal generator output and R.F. **GAIN INCREASE** control for 10 to 1 signal-to-

noise ratio with 10 mw total output. Record signal-to-noise ratio if 10 to 1 cannot be obtained.

(c) Vary the signal generator frequency from 100 mc to 160 mc and record the frequency of all responses which are heard. For each response heard record the μv input necessary to produce 10 mw output.

(d) The undesired response-rejection ratio is the ratio of the signal input at the undesired response frequency to the signal input at the desired signal frequency to give 10 mw output. (*Image frequencies and generator harmonics excepted.*)

(e) Specification requires that this ratio be greater than 10,000 to 1 or 80 db. **NOTE: There should be no beat frequency oscillator harmonics present (harmonics of 6 mc) with the receiver at CW.**

(9) TUNING METER.

(a) Connect the signal generator to the antenna of the receiver through the proper dummy antenna [See section V, paragraph 37b (3)]. Turn modulation **OFF**. Connect the output circuit of receiver to 600-ohm non-inductive load.

(b) Set C.W. AND MANUAL—MANUAL—A.V.C. switch at A.V.C.

(c) Check the position of **THRESHOLD SENSITIVITY** control. It must be set for proper no-signal-noise level (5-10 mw with antenna terminal grounded).

(d) The meter should read about 5 ma with no signal input, provided voltages are normal. Vary the signal input voltage and determine that the results obtained conform to the following;

Input (μv)	Meter Reading (ma)	Change in ma
0	5.0 approx.	0
10	5.0 approx.	0
100	4.8 approx.	> .2
1,000	3.2 approx.	> 1.8
10,000	2.0 approx.	> 3.0
100,000	1.2 approx.	> 3.8

(10) **CALIBRATION ACCURACY.**—Between dial settings of 100 and 156 mc, the calibration accuracy should be better than ± 1 mc. The end points of 100 mc and 156 mc can be made exact by properly adjusting the inductance and capacity of the high frequency oscillator circuit.

38. OUTPUT POWER MEASUREMENTS.

If you can not get an audio power output meter, audio output measurements may be made by con-

necting a 600-ohm non-inductive resistor across the Ballantine Electronic Voltmeter Model 300 or any alternating current voltmeter with 1000- Ω per volt sensitivity or higher and which will measure up to 25v and parallel this combination across the receiver audio output. For a 600-ohm load, the voltmeter readings are converted to milliwatts by the expression:

$$E = .775 \sqrt{P}$$

or

$$P = 1.67 E^2$$

Where E = Volts
and P = Milliwatts

The output power values mentioned in this book are as follows.

E (volts)	P (milliwatts)
.775	1
1.78	5

E (volts)	P (milliwatts)
2.45	10
5.48	50
17.3	500
24.5	1000

39. REPLACING DEFECTIVE COMPONENTS.

When a component is found to be defective replace it with an identical component from the spare parts provided. Check with the data in the Table of Replaceable Parts (section VII, paragraph 44), to be sure that the component is properly identified. The new part must comply in every particular with the data contained therein.

a. Before removing a part from the unit, make a careful note of the leads connected to it and unsolder them. Bend the wires only as much as is necessary to remove the component. *Apply the*

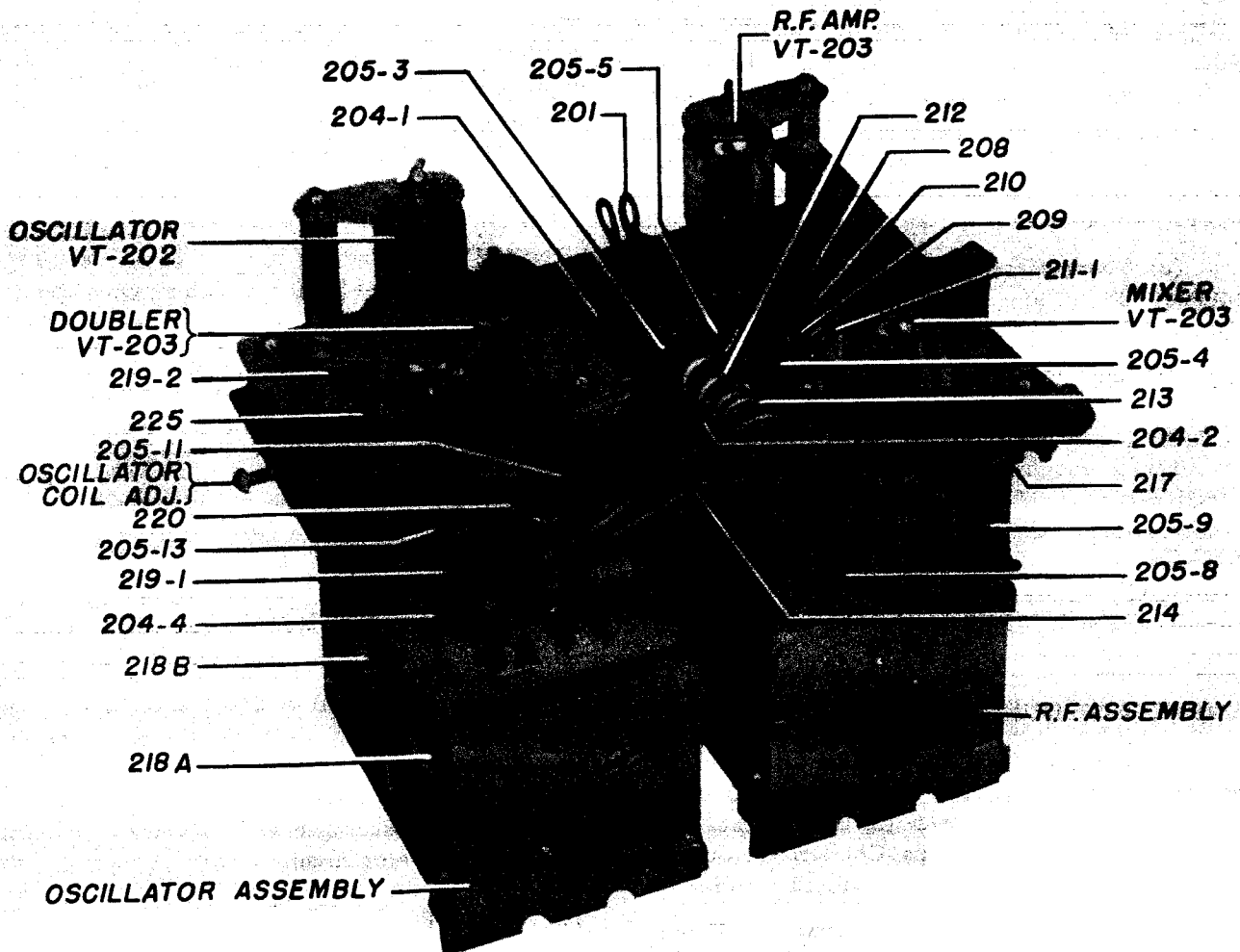

Figure 20 — Radio Receiver BC-639-A, Top Rear Oblique, R. F. and Oscillator Assembly

soldering iron just long enough to soften the soldered joint. Lengthy application of the soldering iron may loosen the terminal or other soldered joints on adjacent components.

b. Components can be removed with a screwdriver, pliers and soldering iron. Washers are provided with all screws. Always replace the washer between the head of the screw and the face of the panel or chassis.

c. When you put in new parts, use the same screws used for the old part whenever they are in good condition. Be careful in tightening the screws not to strip the threads.

d. Use only rosin core solder or special flux intended for radio use. NEVER USE PASTE OR ACID FLUX.

e. Clean and tin both terminal and wire before attempting to make a connection. Fasten the wire mechanically by twisting it around the terminal and clipping the surplus before soldering. Heat the wire and terminal so the solder will flow into the joint. AFTER SOLDERING, DO NOT DISTURB JOINT UNTIL IT COOLS. Remove any excess solder so that it will not cause future short circuits and grounds.

f. Maintenance of switches and relays should not be attempted in the field. All repairs of this unit must be made only by trained personnel equipped with specific maintenance instructions, test equipment, and tools for this purpose.

If the unit fails to operate properly, notify the maintenance depot and do not attempt to use the unit until it is repaired.

40. VACUUM TUBE REPLACEMENT.

a. When a tube fails, replace it. If several tubes fail, it will be best to have the receiver realigned by competent personnel in a properly equipped laboratory or service shop. If complete facilities for realigning the receiver are not available do not attempt realignment as satisfactory operation can still be had.

b. When replacing the oscillator Tube VT-202 in the receiver, it may be necessary to retune the oscillator stage to have the tuning dial indicate exact frequency. THIS ADJUSTMENT MAY BE DONE AND IS THE ONLY INTERNAL ADJUSTMENT PERMITTED TO BE MADE ON THE RECEIVER BY THE STATION OPERATOR.

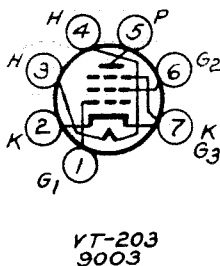
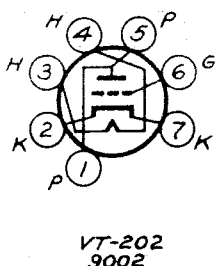
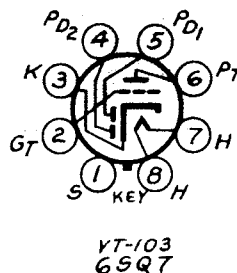
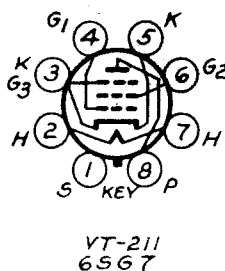
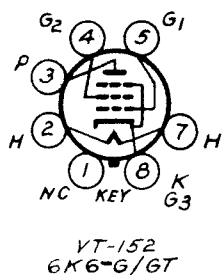

CODE	ELEMENT
G1	CONTROL GRID
G2	SCREEN GRID
G3	SUPPRESSOR GRID
H	HEATER
K	CATHODE
NC	NO CONNECTION
P	PLATE (ANODE)
S	SHELL

ALPHABETICAL SUBSCRIPTS
D, P AND T INDICATE,
RESPECTIVELY, DIODE UNIT,
PENTODE UNIT OR
TRIODE UNIT.

VACUUM TUBE BASE DIAGRAMS
BOTTOM VIEWS ARE SHOWN

Figure 21 — Radio Receiver BC-639-A, Vacuum Tube Base

The procedure is as follows:

(1) Replace the oscillator Tube VT-202. There is only one VT-202 in the receiver; so the proper tube to replace cannot be mistaken.

(2) Tune the receiver to a signal from the frequency meter as close to 156 megacycles, the high end of the band, as possible. Set the dial to read the exact frequency of the incoming signal even though this setting detunes the receiver.

(3) Adjust the trimmer capacitor screw 204-5, (below the oscillator tube) for maximum volume of the signal at this dial setting. **THERE ARE TWO SCREWS BELOW THE OSCILLATOR TUBE. SEE FIG. 15, TO PREVENT MAKING THE WRONG ADJUSTMENT. NEVER ADJUST THE UPPER SCREW.**

NOTE

Use a signal from the frequency meter for the adjustment. The signal must not be too strong, however.

41. PILOT BULB REPLACEMENT.

a. Remove the fifteen round-head screws, including the three screws around the antenna terminal, holding the dust cover on the chassis and remove the dust cover.

b. Remove the burned out bulb by hand. It is a bayonet base bulb and is merely twisted in the socket and removed.

c. Replace with a new 6-8 volt, 0.25 ampere bayonet base bulb, Mazda #44.

d. Replace the dust cover and tighten the fifteen round-head screws, including the three screws around the antenna terminal.

SECTION VII

TABLE OF REPLACEABLE PARTS

MODEL: RADIO RECEIVER BC-639-A

Reference Symbol	Army Stock No. Navy Stock No. British Ref. No.	Name of Part and Description	Function	Mfr. and Desig. or AWS Type	Cont. or Govt. Dwg. or Spec. No.
200	2Z7097-3	PLATE INSULATING ASSEMBLY: Consists of plate, phenolic 1-13/32" diameter, x 1/8" thick, contact socket, 1 contact, overall dim. 1-27/64" x 0.265" O.D. x 0.248" I.D.; spring clip, phosphor bronze 0.010" gauge x 0.475" long x 15/64" I.D.; lock washer No. 1P split, phosphor bronze washer, plain No. 10 BR.; nut 10-32 hex, BR.	Antenna coupling	Bendix	C58585-1
201	2C4439A/A1/1	COIL: Antenna; 2 turns; No. 14 copper wire 5/16" I.D.	Antenna coil	Bendix	A105064
202	2C4439A/A1/2	CAPACITOR: Variable; R-f tuning; 3 section air dielectric; 4-23/32" long x 2" wide x 3-7/16" high; 4 No. 4-40 tap mounting holes, 1 3/4" apart center to center; include trimmers, ref. nos. 204-1 to 3.	R-f tuning	Bendix	L72799-2
203	3D9015-8	CAPACITOR: Fixed; 15 mmf. $\pm 20\%$; Aerovox Type 1468, Cornell-Dubilier, Micamold—O or OXM, Sangamo Type K, Solar—MOFW or MDCW; 5-1/64" x 15/32" x 7/32" maximum; 1 1/4" No. 20 AWG tinned lead, low loss bakelite case. (Note B).	R-f grid coupling	Aerovox, C.D., Micamold, Sangamo, Solar	C58469-150
204-1	2C4439A/A1/3	CAPACITOR: Trimmer; (part of variable capacitor—202). (Note A).	R-f grid trimmer	Bendix	L72799-2
204-2	2C4439A/A1/3	CAPACITOR: Same as 204-1 (Note A).	R-f plate trimmer	Bendix	L72799-2
204-3	2C4439A/A1/3	CAPACITOR: Same as 204-1 (Note A).	Mixer grid trimmer	Bendix	L72799-2
204-4	2C4439A/A2/2	CAPACITOR: Trimmer; (Note A) part of Ref. No. 218.	Doubler plate trimmer	Bendix	L72798-2
204-5	2C4439A/A2/2	CAPACITOR: Same as 204-4 (Note A).	Osc. tank trimmer	Bendix	L72798-2
205-1	3DK9680-5	CAPACITOR: Fixed mica; 680-mmf., 500 Vdcw, $\pm 20\%$; molded bakelite case 1 1/16" x 7/16" x 3/16"; No. 20 AWG tinned leads 1 1/4" long, Aerovox 1468, Dubilier 5LS. (Note A).	R-f a-v-c filter	Aerovox, C.D.	C58469-681
205-2	3DK9680-5	Same as 205-1 (Note A).	R-f cathode bypass	Aerovox, C.D.	C58469-681

Revised 14 August 1944

205-3	3DK9680-5	Same as 205-1 (Note A).	R-f heater bypass	Aerovox, C.D.	C58469-681
205-4	3DK9680-5	Same as 205-1 (Note A).	R-f plate to cathode bypass	Aerovox, C.D.	C58469-681
205-5	3DK9680-5	Same as 205-1 (Note A).	R-f screen bypass	Aerovox, C.D.	C58469-681
205-6	3DK9680-5	Same as 205-1 (Note A).	R-f plate to ground bypass	Aerovox, C.D.	C58469-681
205-7	3DK9680-5	Same as 205-1 (Note A).	Mixer cathode bypass	Aerovox, C.D.	C58469-681
205-8	3DK9680-5	Same as 205-1 (Note A).	Mixer heater bypass	Aerovox, C.D.	C58469-681
* 205-9	3DK9680-5	Same as 205-1 (Note A).	Mixer Screen bypass	Aerovox, C.D.	C58469-681
205-10	3DK9680-5	Same as 205-1 (Note A).	Doubler plate bypass	Aerovox, C.D.	C58469-681
205-11	3DK9680-5	Same as 205-1 (Note A).	Doubler Screen bypass	Aerovox, C.D.	C58469-681
205-12	3DK9680-5	Same as 205-1 (Note A).	Doubler cathode bypass	Aerovox, C.D.	C58469-681
205-13	3DK9680-5	Same as 205-1 (Note A).	Doubler heater bypass	Aerovox, C.D.	C58469-681
205-14	3DK9680-5	Same as 205-1 (Note A).	Osc. heater bypass	Aerovox, C.D.	C58469-681
206	3Z6700-71	RESISTOR: Fixed; carbon; 100,000 ohms, $\pm 20\%$, $\frac{1}{2}$ watt; $\frac{3}{8}$ " long x $\frac{9}{64}$ " dia., No. 20 leads $1\frac{1}{2}$ " long; Allen Bradley Type EB; Speer Type SI- $\frac{1}{2}$. (Note B).	R-f a-v-c filter	Allen-Bradley, Speer	A112927-104
207	3Z6756-5	RESISTOR: Fixed; composition; 560,000 ohms $\pm 10\%$, $\frac{1}{2}$ watt; $\frac{3}{8}$ " long x $\frac{9}{64}$ " dia.; No. 20 leads $1\frac{1}{2}$ " long; Allen-Bradley Type EB; Speer Type SI- $\frac{1}{2}$. (Note B).	R-f grid leak	Allen-Bradley, Speer	A32298-564
208	3Z6033-13	RESISTOR: Fixed; composition; 330 ohm, $\pm 10\%$, $\frac{1}{2}$ watt; $\frac{3}{8}$ " long x $\frac{5}{32}$ " dia.; No. 20 leads $1\frac{1}{2}$ " long; Allen-Bradley Type EB; I.R.C. BTS; Speer Type SI- $\frac{1}{2}$. (Note B).	R-f cathode bias	Allen-Bradley I.R.C., Speer	A32298-331

Note A.—Replace entire assembly in which this item is used.

Note B.—Replaceable with difficulty. Replace entire assembly in which item is used whenever possible.

*Any value from 600 to 1,000 mmf. acceptable. See table for alternate preference.

MODEL: RADIO RECEIVER BC-639-A

Reference Symbol	Army Stock No. Navy Stock No. British Ref. No.	Name of Part and Description	Function	Mfr. and Desig. or AWS Type	Cont. or Govt. Dwg. or Spec. No.
209	3Z6712-3	RESISTOR: Fixed; composition; 120,000 ohms $\pm 10\%$, $\frac{1}{2}$ watt; $\frac{3}{8}$ " long x $\frac{5}{32}$ " dia.; No. 20 leads $\frac{1}{2}$ " long; Allen-Bradley Type EB; Speer Type SI- $\frac{1}{2}$. (Note B).	R-f screen bleeder	Allen-Bradley, Speer	A32298-124
210	3ZK6639-15	RESISTOR: Fixed; composition; 39,000 ohms, $\pm 10\%$; Allen-Bradley Type GB-1; $\frac{9}{16}$ " long x $\frac{7}{32}$ " dia., No. 18 leads $\frac{1}{2}$ " long. (Note B).	R-f screen dropping	Allen-Bradley	A112933-393
211-1	3Z6100-75	RESISTOR: Fixed; composition; 1000 ohms, $\pm 20\%$; $\frac{1}{2}$ watt; $\frac{3}{8}$ " long x $\frac{9}{64}$ " dia.; No. 20 tinned leads $\frac{1}{2}$ " long; Allen-Bradley Type EB; Speer Type SI- $\frac{1}{2}$. (Note B).	R-f plate dropping	Allen-Bradley, Speer	A112927-102
211-2		Same as 211-1.	Mixer cathode bias	Allen-Bradley, Speer	A32014-102
212	3C1074-8	COIL: Inductor; 2 turns No. 14 AWG (.064) soft drawn tinned copper wire. (Note A).	R-f plate coil	Bendix	A105065
213	3C1074-9	COIL: Inductor; 2 turns No. 14 AWG soft drawn tinned copper wire $\frac{9}{32}$ " I.D. (Note A).	Mixer grid coil	Bendix	A105066
214	3C1074-10	COIL: 1 turn No. 12 B & S gauge .080 soft drawn tinned copper wire, $\frac{3}{8}$ " I.D.; ends $\frac{19}{32}$ " apart; $2\text{-}\frac{35}{64}$ " long x $\frac{25}{32}$ " width. (Note A).	Doubler plate coil	Bendix	A104311
215-1	3D9047-7	CAPACITOR: Fixed; silver mica; 47 mmf., $\pm 20\%$, 500 VDCW; Aerovox Type 1468, Cornell Dubilier; Micamold, Sangamo and Solar; $\frac{11}{16}$ " long x $\frac{7}{16}$ " wide x $\frac{13}{64}$ " thick; No. 20 AWG tinned leads $\frac{1}{4}$ " long. (Note A).	Mixer grid coupling	Aerovox, C.D. Micamold, Sangamo, Solar	C58469-470
215-2	3D9047-7	Same as 215-1. (This is replaceable).	A-v-c diode coupling	Aerovox, C.D. Micamold, Sangamo, Solar	C58469-470
216	3Z6801A8	RESISTOR: Fixed; composition; 1.8 megohm $\pm 10\%$; $\frac{3}{8}$ " long x $\frac{5}{32}$ " dia.; No. 20 leads $\frac{1}{2}$ " long; Allen-Bradley Type EB; Speer Type No. SI- $\frac{1}{2}$. (Note B).	Mixer grid leak	Allen-Bradley, Speer	A32298-185
217	3Z6727-9	RESISTOR: Fixed; composition; 270,000 ohms $\pm 10\%$, $\frac{1}{2}$ watt; $\frac{3}{8}$ " long x $\frac{5}{32}$ " dia.; No. 20 leads $\frac{1}{2}$ " long; Allen-Bradley Type EB; Speer Type No. SI- $\frac{1}{2}$. (Note B).	Mixer screen dropping	Allen-Bradley, Speer	A32298-274
218	2C4439A/A2/1	CAPACITOR: Variable; air dielectric; 2 sections, O-39.6 mmf. and O-36 mmf.; 100% rotation; $3\text{-}\frac{17}{64}$ " long x 2" wide x $3\text{-}\frac{7}{16}$ " high, 4 mounting holes No. 4-40 tap, $\frac{1}{4}$ " apart.	Osc. and doubler tuning	Bendix	L72798-2

Revised 14 August 1944

AN 08-40BC639-2

Section VII

219-1	3Z6470-14	RESISTOR: Fixed; composition; 4700 ohms $\pm 20\%$, $\frac{1}{2}$ watt; $\frac{3}{8}$ " long x $\frac{9}{64}$ " dia.; No. 20 AWG tinned copper leads $1\frac{1}{2}$ " long; Allen-Bradley Type EB; Speer Type No. SI- $\frac{1}{2}$. (Note B).	Doubler plate filter	Allen-Bradley, Speer	A112927-472
219-2	3Z6470-14	Same as 219-1. (Note B).	Osc. plate filter	Allen-Bradley, Speer	A112927-472
220	3Z6656-3	RESISTOR: Fixed; composition; 56,000 ohms $\pm 10\%$, $\frac{1}{2}$ watt; $\frac{3}{8}$ " long x $\frac{9}{64}$ " dia.; No. 20 leads $1\frac{1}{2}$ " long; Allen-Bradley Type EB; Speer Type No. SI- $\frac{1}{2}$. (Note B). (Alternate ASARC20-BF563I).	Doubler screen dropping	Allen-Bradley, Speer	A32298-563
221	3Z6056-2	RESISTOR: Fixed; composition; 560 ohms $\pm 10\%$, $\frac{1}{2}$ watt; $\frac{3}{8}$ " long x $\frac{9}{64}$ " dia.; No. 20 leads $1\frac{1}{2}$ " long; Allen-Bradley Type EB; Speer Type No. SI- $\frac{1}{2}$. (Note B). (Alternate ASARC205BF-561J).	Doubler cathode bias	Allen-Bradley, Speer	A32298-561
222	3Z6627-7	RESISTOR: Fixed; composition; 27,000 ohms $\pm 10\%$, $\frac{1}{2}$ watt; $\frac{3}{8}$ " long x $\frac{9}{64}$ " dia.; No. 20 leads $1\frac{1}{2}$ " long; Allen-Bradley Type EB; Speer Type No. SI- $\frac{1}{2}$. (Note B). (Alternate ASARC20BF-273K).	Doubler grid leak	Allen-Bradley, Speer	A32298-273
223	3C1074-11	COIL: Inductor; 7 turns No. 18 AWG .040 soft drawn tinned copper wire. (Note A).	H-f osc. coil	Bendix	A105061
224	3D9027-5	CAPACITOR: Fixed; mica, 27 mmf. $\pm 20\%$; 500V dcw; Aerovox Type 1468; Cornell-Dubilier 5WST; Micamold O or OXM; Sangamo—K; Solar MOFW or MDCW; $11/16$ " long x $7/16$ " wide x $13/64$ " thick; $1\frac{1}{2}$ " leads No. 20 AWG tinned wire. (Note B). (Alternate 33 mmf. $\pm 20\%$; 500 DCW; AWACM20B330M).	Doubler grid coupling	C.D., Aerovox Micamold, Sangamo, Solar	C58469-270
225	3DK9150-24	CAPACITOR: Fixed; mica; 150 mmf. $\pm 20\%$; 500V dcw; Aerovox Type 1468; $11/16$ " long x $7/16$ " wide x $13/64$ " thick; $1\frac{1}{4}$ " leads No. 20 AWG tinned. (Note B). (Alternate CM20B151M).	Osc. plate bypass	C.D., Aerovox	C58469-151
226	3Z6647-26	RESISTOR: Fixed; composition; 47,000 ohms $\pm 20\%$, $\frac{1}{2}$ watt; $\frac{3}{8}$ " long x $\frac{9}{64}$ " dia.; No. 20 leads $1\frac{1}{2}$ " long; Allen-Bradley Type EB; Speer Type No. SI- $\frac{1}{2}$. (Note B). (Alternate ASARC20BF-473M).	Osc. grid leak	Allen-Bradley, Speer	A112927-473
227-1	3D9015-9	CAPACITOR: Fixed; 15 mmf; $\pm 5\%$; 500V. d.c.w.; Erie Type N750-K; modified.	1st i-f pri. tuning temp. comp.	Erie	A25715-15
227-2	3D9015-9	Same as 227-1.	1st i-f sec. tuning temp. comp.	Erie	A25715-15

Note A.—Replace entire assembly in which this item is used.

Note B.—Replaceable with difficulty. Replace entire assembly in which item is used whenever possible.

*Any value from 600 to 1,000 mmf. acceptable. See table for alternate preference.

50 MODEL: RADIO RECEIVER BC-639-A

Reference Symbol	Army Stock No. Navy Stock No. British Ref. No.	Name of Part and Description	Function	Mfr. and Desig. or AWS Type	Cont. or Govt. Dwg. or Spec. No.
227-3	3D9015-9	Same as 227-1.	2nd i-f pri. tuning temp. comp.	Erie	A25715-15
227-4	3D9015-9	Same as 227-1.	2nd i-f sec. tuning temp. comp.	Erie	A25715-15
227-5	3D9015-9	Same as 227-1.	3rd i-f pri. tuning temp. comp.	Erie	A25715-15
227-6	3D9015-9	Same as 227-1.	3rd i-f sec. tuning temp. comp.	Erie	A25715-15
227-7	3D9015-9	Same as 227-1.	4th i-f pri. tuning temp. comp.	Erie	A25715-15
227-8	3D9015-9	Same as 227-1.	4th i-f sec. tuning temp. comp.	Erie	A25715-15
228-1	3D9060-1	CAPACITOR: Fixed; mica; 60 mmf.; $\pm 2\%$; 500V d.c.w.; 1000 v.d. c.t.; 11/16" long x 7/16" high x 3/16" wide; No. 20 AWG leads 1/4" long; Aerovox Type 1469, Dubilier 5R.	1st i-f pri. tuning	Aerovox, C.D.	C58495-600
228-2	3D9060-1	Same as 228-1.	1st i-f sec. tuning	Aerovox, C.D.	C58495-600
228-3	3D9060-1	Same as 228-1.	2nd i-f pri. tuning	Aerovox, C.D.	C58495-600
228-4	3D9060-1	Same as 228-1.	2nd i-f sec. tuning	Aerovox, C.D.	C58469-600
228-5	3D9060-1	Same as 228-1.	3rd i-f pri. tuning	Aerovox, C.D.	C58469-600
228-6	3D9060-1	Same as 228-1.	3rd i-f sec. tuning	Aerovox, C.D.	C58469-600
228-7	3D9060-1	Same as 228-1.	4th i-f pri. tuning	Aerovox, C.D.	C58469-600

Revised 14 August 1944

AN 08-40BC639-2

Section VIII

228-8	3D9060-1	Same as 228-1.	4th i-f sec. tuning	Aerovox, C.D.	C58469-600
229-1	3C610	INDUCTOR: 10 turns No. 22 enameled wire; primary coil of assembly 231. (Note B).	Mixer plate coil	Bendix	A104206-1
229-2	3C610	SECONDARY COIL OF ASSEMBLY 231: Same as 229-1. (Note B).	1st i-f grid coil	Bendix	A104206-1
229-3	3C610	PRIMARY COIL OF ASSEMBLY 232: Same as 229-1. (Note B).	1st i-f plate coil	Bendix	A104206-1
229-4	3C610	SECONDARY COIL OF ASSEMBLY 232: Same as 229-1. (Note B).	2nd i-f grid coil	Bendix	A104206-1
229-5	3C610	PRIMARY COIL OF ASSEMBLY 233: Same as 229-1. (Note B).	2nd i-f plate coil	Bendix	A104206-1
229-6	3C610	SECONDARY COIL OF ASSEMBLY 233: Same as 229-1. (Note B).	3rd i-f grid coil	Bendix	A104206-1
229-7	3C610	PRIMARY COIL OF ASSEMBLY 234: Same as 229-1. (Note B).	3rd i-f plate coil	Bendix	A104206-1
229-8	3C610	SECONDARY COIL OF ASSEMBLY 234: Same as 229-1. (Note B).	2nd det. diode coil	Bendix	A104206-1
230-1	3K3562222	CAPACITOR: Molded mica dielectric type; 6200 MMF; - / 5%; 500V dcw; CM35B 622J; A.F. 3330-376154600.	Mixer plate bypass		
230-2	3K3562222	Same as 230-1.	H-V filter		
230-3	3K3562222	Same as 230-1.	1st i-f a-v-o filter		
230-4	3K3562222	Same as 230-1.	1st i-f cathode bypass		
230-5	3K3562222	Same as 230-1.	1st i-f screen bypass		
230-6	3K3562222	Same as 230-1.	1st i-f plate bypass		
230-7	3K3562222	Same as 230-1.	2nd i-f a-v-c filter		

Note A.—Replace entire assembly in which this item is used.

Note B.—Replaceable with difficulty. Replace entire assembly in which item is used whenever possible.

*Any value from 600 to 1,000 mmf. acceptable. See table for alternate preference.

MODEL: RADIO RECEIVER BC-639-A

<i>Reference Symbol</i>	<i>Army Stock No. Navy Stock No. British Ref. No.</i>	<i>Name of Part and Description</i>	<i>Function</i>	<i>Mfr. and Desig. or AWS Type</i>	<i>Cont. or Govt. Dwg. or Spec. No.</i>
230-8	3K3562222	Same as 230-1.	2nd i-f cathode bypass		
230-9	3K3562222	Same as 230-1.	2nd i-f screen bypass		
230-10	3K3562222	Same as 230-1.	2nd i-f plate bypass		
230-11	3K3562222	Same as 230-1.	3rd i-f grid bypass		
230-12	3K3562222	Same as 230-1.	3rd i-f cathode bypass		
230-13	3K3562222	Same as 230-1.	3rd i-f heater bypass		
230-14	3K3562222	Same as 230-1.	3rd i-f screen bypass		
230-15	3K3562222	Same as 230-1.	3rd i-f plate bypass		
230-16	3K3562222	Same as 230-1.	A-v-c bus filter		
230-17	3K3562222	Same as 230-1.	1st a-f grid coupling		
230-18	3K3562222	Same as 230-1.	2nd a-f grid coupling		
230-19	3K3562222	Same as 230-1.	CW osc. plate bypass		
230-20	3K3562222	Same as 230-1.	CW osc. screen (anode) bypass		
230-21	3K3562222	Same as 230-1.	1st i-f cathode bypass		
230-22	3K3562222	Same as 230-1.	2nd i-f cathode bypass		

Revised 10 September 1956

230-23	3K3562222	Same as 230-1.	3rd i-f cathode bypass		
230-24	3K3562222	Same as 230-1.	CW osc. heater bypass		
231	2Z10001.2	TRANSFORMER: 1st I.F. Assy.; 12 mc.; permeability tuned, adjustable iron core; includes 5 capacitors; metal can $3\frac{3}{8}$ " x 2" x $1\frac{17}{32}$ "; 4 sub-chassis solder lug terminals; 2 flexible leads from side, mounted upright; mounting centers $1\frac{7}{8}$ "; transformer over-coupled to provide double hump 30 kc apart; includes 229-1, 229-2, 227-1, 227-2, 228-1, 228-2, 230-1.	1st i-f assembly	Bendix	L73530-1
232	2Z10001.11	TRANSFORMER: 2nd I.F. Assy.; 12 mc.; permeability tuned, adjustable iron core; includes 4 capacitors; metal can $3\frac{3}{8}$ " x 2" x $1\frac{11}{32}$ "; 4 sub-chassis solder lug terminals mounted upright; mounting centers $1\frac{7}{8}$ ". Transformer over-coupled to provide double hump 30 kc apart; includes 229-3, 229-4, 227-3, 227-4, 228-3, 228-4.	2nd i-f assembly	Bendix	L73531-1
233	2Z10001.5	TRANSFORMER: 3rd I.F. Assy.; 12 mc.; permeability tuned two adjustments, one for the primary and one for the secondary; mounted in an aluminum can $1\frac{1}{2}$ " x 2" x $3\frac{11}{16}$ " which mounts by two threaded studs on the bottom of the case on $1\frac{7}{8}$ " centers; 4 solder lug terminals on the bottom of unit. Transformer designed for optimum coupling with single peak response at 12 mc.; includes 229-5, 229-6, 227-5, 227-6, 228-5, 228-6.	3rd i-f assembly	Bendix	L73026-4
234	2Z10001.8	TRANSFORMER: 4th I.F. Assy.; 12 mc.; permeability tuned, 2 adjustments, one for primary and one for secondary; mounted in an aluminum can $1\frac{1}{2}$ " x 2" x $3\frac{11}{16}$ " which is mounted upright; mounting centers $1\frac{7}{8}$ "; 4 solder lug terminals on bottom of unit; transformer designed for peak response at 12 mc. with internal connections to the coil windings, so arranged to give reversal of the polarity between the primary and secondary, altering the resonant curve; includes 229-7, 229-8, 227-7, 227-8, 228-7, 228-8.	4th i-f assembly	Bendix	L73028-2
235-1	3Z6100-121	RESISTOR: Fixed; composition; 1000 ohm $\pm 20\%$, 1 watt; $9/16$ " long x $7/32$ " dia.; No. 18 tinned copper leads $1\frac{1}{2}$ " long; Allen-Bradley Type GB. (Alternate ASARC20BF102M).	Mixer plate filter	Allen-Bradley	A112931-102
235-2	3Z6100-121	Same as 235-1.	1st i-f plate filter	Allen-Bradley	A112931-102
235-3	3Z6100-121	Same as 235-1.	2nd i-f plate filter	Allen-Bradley	A112931-102

Note A.—Replace entire assembly in which this item is used.

Note B.—Replaceable with difficulty. Replace entire assembly in which item is used whenever possible.

*Any value from 600 to 1,000 mmf. acceptable. See table for alternate preference.

54 MODEL: RADIO RECEIVER BC-639-A

Reference Symbol	Army Stock No. Navy Stock No. British Ref. No.	Name of Part and Description	Function	Mfr. and Desig. or AWS Type	Cont. or Govt. Dwg. or Spec. No.
235-4	3Z6100-121	Same as 235-1.	3rd i-f plate filter	Allen-Bradley	A112931-102
236-1	3Z6700-74	RESISTOR: Fixed; composition; 100,000 ohms $\pm 20\%$, 1 watt; 9/16" long x 7/32" dia.; No. 18 tinned copper leads 1 1/2" long; Allen-Bradley Type GB No. 1042. (Alternate ASARC20BF104M).	1st i-f a-v-c filter	Allen-Bradley	A112931-104
236-2	3Z6700-74	Same as 236-1.	2nd i-f a-v-c filter	Allen-Bradley	A112931-104
236-3	3Z6700-74	Same as 236-1.	3rd i-f grid leak	Allen-Bradley	A112931-104
236-4	3Z6700-74	RESISTOR: Fixed; composition; 100,000 ohms $\pm 10\%$, 1 watt; Bakelite insulation; 9/16" long x 7/32" dia.; No. 18 leads 1 1/2" long; Allen-Bradley Type GB.	A-f diode load	Allen-Bradley	A112933-104
236-5	3Z6700-74	Same as 236-4.	A-f diode load	Allen-Bradley	A112933-104
237-1	3RC20AE22/J	RESISTOR: Fixed; composition; 220 ohms $\pm 5\%$; 1 watt; 9/16" long x 7/32" dia., leads No. 18 wire 1 1/2" long; Allen-Bradley Type GB-2211. (Alternate RC20BF221M).	1st i-f cathode bias	Allen-Bradley	A112933-221
237-2	3RC20AE22/J	Same as 237-1.	2nd i-f cathode bias	Allen-Bradley	A112933-221
237-3	3RC20AE22/J	Same as 237-1.	3rd i-f cathode bias	Allen-Bradley	A112933-221
237-4	3Z6022-25	RESISTOR: Fixed; carbon; 220 ohms, $\pm 20\%$, 1 watt; 9/16" long x 7/32" dia., No. 18 leads 1 1/2" long. Allen-Bradley Type GB.	CW osc. grid parasitic suppressor	Allen-Bradley	A112931-221
238-1	3Z6647-19	RESISTOR: Fixed; composition; 47,000 ohms $\pm 10\%$, 1 watt; Bakelite insulated; 9/16" long x 7/32" dia., No. 18 leads 1 1/2" long. Allen-Bradley Type GB. (Alternate ASARC20BF473M).	1st i-f screen dropping	Allen-Bradley	A112933-473
238-2	3Z6647-19	Same as 238-1.	2nd i-f screen dropping	Allen-Bradley	A112933-473
238-3	3Z6647-19	Same as 238-1.	3rd i-f screen dropping	Allen-Bradley	A112933-473
238-4	3Z6647-19	Same as 238-1.	CW osc. grid leak	Allen-Bradley	A112933-473

Revised 14 August 1944

T.O. 31R2-3BC639-22

Section VII

239-1	3DB1.484	CAPACITOR: Fixed; paper; oil; 1 mfd. 10%, 100 v.d.c.w.; metal case; 1-13/16" long x 1" wide, overall length 2 1/2"; 2 insulated terminals; 2-3/16" dia. mounting holes 2 1/8" centers.	Sens. control bus bypass	Aerovox	A104484
239-2	3DB1.484	Same as 239-1.	2nd audio cathode bypass	Aerovox	A104484
240	3F901-5	METER: 0-10 milliamperes; D.C.; Weston Model 506 (3) 1/8" holes, mounting 1-5/32" from center of meter 2 1/2" flush; GE Model DW 51, Westinghouse Model MX.	TUNING METER	Weston, Westinghouse, G.E.	A104194-4
241	2Z7262-3	POTENTIOMETER: "THRESHOLD SENSITIVITY"; 300 ohm, $\pm 20\%$ linear taper; Allen-Bradley Type "J" Bradleyometer; 1-1/16" dia. 9/16" deep; .25" dia. shaft, 1/8" long; screw adj.; no flat on shaft; 3/8"-32 thread mounting 1/4" long.	THRESHOLD SENSITIVITY control	Allen-Bradley	A105022
242	2Z7262-3M	POTENTIOMETER: Sensitivity control; 3000 ohms $\pm 20\%$; Allen-Bradley Type "J"; 1-1/16" dia. x 9/16" deep; .25" dia. shaft 3/4" long; 3 contacts.	R-f gain control	Allen-Bradley	C58961
243	3Z9825-32	SWITCH: 3 position; 5 contact; "C.W. MANUAL—AVC"; shorting type; 1/4" shaft x .25" dia. x 3/4" long.	Selector switch	Mallory	C58583
244-1	3Z6801-43	RESISTOR: Fixed; composition; 1 megohm $\pm 20\%$, 1/2 watt; No. 1052; 3/8" long x 9/64" dia.; No. 20 AWG leads 1 1/2" long. Allen-Bradley Type EB. Speer Type No. SI-1/2. (Alternate ASARC20-BF105M).	A-v-c diode load	Allen-Bradley, Speer	A112927-105
244-2	3Z6801-43	Same as 244-1.	A-v-c bus filter	Allen-Bradley, Speer	A112927-105
245-1	3D9330-4	CAPACITOR: Fixed; mica; 330 mmf. $\pm 20\%$, 500 v.d.c.w., 1000 v.d.c.t.; 11/16" long x 7/16" wide x 13/64" thick; No. 20 AWG leads 1 1/4" long, Aerovox Type 1468ST; C.D. Type 5WST or 5WLST, Micamold Type O or OXM, Sangamo Type K, Solar Type MOFW or MOCW. (Alternate ASACM20B331N).	A-f diode load filter	C.D., Aerovox, Micamold, Sangamo, Solar	C58469-331
245-2	3D9330-4	Same as 245-1.	1st audio plate r-f bypass	C.D., Aerovox, Micamold, Sangamo, Solar	C58469-331
246	3D9001E8	CAPACITOR: Fixed; mica; 1.8 mmf. $\pm 50\%$, 500 v.d.c.t.; Aerovox Type 1468, 11/16" long x 3/16" deep x 7/16" wide, 1/4" leads.	CW osc. coupling	Aerovox	C56336-18

Note A.—Replace entire assembly in which this item is used.

Note B.—Replaceable with difficulty. Replace entire assembly in which item is used whenever possible.

*Any value from 600 to 1,000 mmf. acceptable. See table for alternate preference.

MODEL: RADIO RECEIVER BC-639-A

Reference Symbol	Army Stock No. Navy Stock No. British Ref. No.	Name of Part and Description	Function	Mfr. and Desig. or AWS Type	Cont. or Govt. Dwg. or Spec. No.
247	3D9220-1	CAPACITOR: Fixed; mica; 220 mmf. \pm 20%, 500 d.c.w., 1000 v.d.c.t.; 11/16" long x 7/16" wide x 13/64" thick, No. 20 AWG leads 1-1/4" long, Aerovox 1468ST or 1468 LST, Micamold Type O or OXM, Sangamo Type K, Solar Type MOFW or MOCW. (Alternate ASACM20B2211Z).	A-f diode load filter	Aerovox, C.D., Micamold, Sangamo, Solar	C58469-221
248	3DA100-124	CAPACITOR: Fixed; paper; 0.1 mfd. \pm 10%, 400 v.d.c.w.; moulded case, brown or black phenolic; Micamold or Solar; 1-29/64" long x 49/64" wide x 25/64" high. No. 18 leads 1-1/8" long.	1st audio cathode bypass	Micamold, Solar	A18015-104
249	3ZK6618-24	RESISTOR: Fixed; composition; 18,000 ohms \pm 10%, 1 watt; Allen-Bradley Type GB; Bakelite insulation; 9/16" long x 7/32" dia. No. 18 AWG leads 1-1/2" long. (Alternate ASARC20BF-183J).	A-v-c-delay	Allen-Bradley	A112933-183
250	3RC20AE22J	RESISTOR: Fixed; composition; 2200 ohms \pm 5%, 1 watt; Allen-Bradley Type GB; Bakelite insulated; 9/16" long x 7/32" dia. No. 18 AWG leads 1-1/2" long. (Alternate ASARC20BF222K).	1st audio bias	Allen-Bradley	A112933-222
251	2Z7262.1	POTENTIOMETER: Audio volume control; 1 megohm; Allen-Bradley Type "J" Bradleyometer Y-3986-D; 1-1/16" dia. x 9/16" deep, .25" dia. shaft; no switch; 3/4" long shaft 3/8-32 thread mounting.	Audio volume control	Allen-Bradley	A102616
252	3Z6568-5	RESISTOR: Fixed; composition; 68,000 ohms \pm 10%, 1/2 watt; Allen-Bradley Type EB; Bakelite insulated; 3/8" long x 5/32" dia. No. 20 AWG leads 1-1/2" long. (Alternate ASARC20BF683J).	Audio attenuator	Allen-Bradley	A32298-683
253-1	3ZK6633-20	RESISTOR: Fixed; composition; 33,000 ohms \pm 10%, 1/2 watt; Allen-Bradley Type EB; 3/8" long x 9/64" dia.; No. 20 AWG leads 1-1/2" long. (Alternate ASARC20BF33J).	Audio attenuator	Allen-Bradley	A32298-333
253-2	3ZK6633-20	Same as 253-1	Audio attenuator	Allen-Bradley	A32298-333
254	3Z9825-33	SWITCH: 3 position; 6 lugs shorting type; mounting bushing 3/4" long x 3/8"-32 thread, shaft 1/4" dia. x 1/2" long.	Attenuator switch	Mallory	C58584
255	3Z6733-8	RESISTOR: Fixed; carbon; 330,000 ohms \pm 20%, 1 watt; Allen-Bradley Type GB; 9/16" long x 7/32" dia., No. 18 leads 1-1/2" long. (Alternate 330,000 ohms \pm 20%, 1/2 watt; ASARC20BF).	2nd audio grid leak	Allen-Bradley	A112931-334
256	3RC41BE561J	RESISTOR: Fixed; carbon; 560 ohms \pm 5%, 2 watt; JAN Type, No. RC41BE561J.	2nd Audio cathode bias	JAN	

257	3DA6.800	CAPACITOR: Fixed; paper; .0068 mfd. $\pm 10\%$; 300 v.d.c.w.; moulded case; BM-120 Bakelite, wax impregnated; 600 v.d.c.t., 53/64" long x 17/64" wide x 53/64" high, No. 20 AWG tinned leads, 1 1/8" long. (Alternate CM35B682K).	Output trans. tuning	Aerovox, Solar, C.D.	A25714-7
258	2Z10000-10	TRANSFORMER: Audio transformer; output level, 1 watt, ± 3 DB for 300-3000 cycles, primary Z=12,500 ohms; Sec. Z=600 ohms; turns ratio P to S 4.56-1; Pri Res. 300 ohms, Sec. Res. 22 ohms, 1500 V.R.M.S. at 60 cycle test; 1 1/8" long x 1-7/16" wide x 1 1/8" high; 5 terminals (4) No. 6-32 thread 1/4" deep spaced 1 3/8" and 1" mounting holes.	Audio output	Bendix	A103058
259	2Z10000.1/1	COIL: (primary of transformer 2Z10000-10). (Note A).	Audio transformer primary	Bendix	A103058
260	2Z10000.1/2	COIL: (secondary of transformer 2Z10000-10). (Note A).	Audio transformer secondary	Bendix	A103058
261	3Z6470-15	RESISTOR: Fixed; composition; 4700 ohms $\pm 20\%$, 1/2 watt; Allen-Bradley Type GB No. 4722; 9/16" long x 7/32" dia.; No. 18 tinned leads 1 1/2" long. (Alternate 4700 ohms; $\pm 20\%$, 1/2 watt; ASARC20BF472M).	Output trans. center tap grounding	Allen-Bradley	A112931-472
262-1	2Z5542	JACK JK-42: Phone; tip, ring and sleeve contacts; same as West. Elec. Co. Type 239-A; 3-23/64" long x 9/16" dia., dia. plug hole .2515" min. .253" max.; 2 contacts open when plug is inserted.	Monitor jack	West. Electric	A103533
262-2	2Z5542	Same as 262-1.	Tel. line jack	West. Electric	A103533
263	2Z7228-14.1	PLUG: Jones Type P-406-AB-3/4; 6 prong; No. 20 drill mounting hole 2.312" apart.	Power cable plug	Jones	A105106
264	3Z6470-15	Same as 261. (Alternate 4700 ohms $\pm 20\%$; 1 watt; ASARC30BF-472M).	CW osc. plate dropping	Allen-Bradley	A112931-472
265	3D9100-63	CAPACITOR: Fixed; silver mica; 100 mmf. $\pm 10\%$; 500 v.d.c.w.; 11/16" long x 7/16" wide x 3/16" thick, leads 1 1/4" long, Aerovox Type 1469; C.D. Type 5R. (Alternate ASACM-20B101K).	CW osc. plate tuning	Aerovox, C.D.	C56318-101
266	3C336-23	COIL ASSEMBLY: 10 turns No. 22 DCC wire on moulded form (phenolic); 1-23/32" long x 11/16" dia. threaded 1/32" one end.	CW osc. plate coil	Bendix	A106068-1

Note A.—Replace entire assembly in which this item is used.

Note B.—Replaceable with difficulty. Replace entire assembly in which item is used whenever possible.

*Any value from 600 to 1,000 mmf. acceptable. See table for alternate preference.

MODEL: RADIO RECEIVER BC-639-A

Reference Symbol	Army Stock No. Navy Stock No. British Ref. No.	Name of Part and Description	Function	Mfr. and Desig. or AWS Type	Cont. or Govt. Dwg. or Spec. No.
267	3D9004E7	CAPACITOR: Fixed; mica; 4.7 mmf. $\pm 20\%$, 500 v.d.c.w., 1000 v.d.c.t.; 11/16" long x 7/16" wide x 13/64" thick, No. 20 tinned 1/4" leads, Aerovox Type 1468ST or 1468LST; Dubilier 5WLST, Micamold Type O or OXM, Sangamo Type K, Solar Type MOFW or MOCW. (Alternate 50 mmf. $\pm 20\%$; 500 v.d.c. —ASACM20B050M).	CW osc. coupling	Aerovox, C.D. Micamold, Sangamo, Solar	C58469-047
268	3Z6647-19	RESISTOR: Fixed; composition; 47,000 ohms $\pm 10\%$, 1 watt; Allen-Bradley Type GB; Bakelite insulated; 9/16" long x 7/32" dia., No. 18 leads 1/2" long. (Alternate 47,000 ohms $\pm 5\%$, 1 watt; ASARC30BF473J).	CW osc. screen (anode) dropping	Allen-Bradley	A112933-473
269	2C4439A/A3/2	INDUCTOR: Coil assembly; 10 turns No. 22 DCC wire, tapped 4 1/2 turns from end opposite core adjusting screw; part of BFO can assembly No. 3C4439A/A3. (Note A).	CW osc. grid coil	Bendix	A105036-1
270	3D9008V-4	CAPACITOR: Variable; 8-10 mmf.; 2 rotors, 2 strators, 15/16" wide x 1-7/32" high, .25" dia. shaft. Hammerlund Type APC. (Note B).	CW osc. heat frequency control	Hamm.	A105041
271	3D9390	CAPACITOR: Fixed; mica; 390 mmf. $\pm 5\%$, 500 v.d.c.w.; 11/16" long x 3/16" deep x 7/16" wide. No. 20 tinned leads 1/4" long. Aerovox Type 1469, C.D. Type 5R. (Note B). (Alternate ASA-CM20B391J).	CW osc. grid tuning	Aerovox, C.D.	C56317-391
272	2C4439A/A3	B.F.O. CAN ASSEMBLY: 3" high x 1 1/2" x 2" base; 3 terminals; contains Ref. Nos. 269, 270, 271, 276-2.	Beat freq. osc.	Bendix	C58590-1
273	2Z8723.1	SOCKET: Dial light; for bayonet base type bulb; Amer. Radio Hdwe. Co. similar to Cat. No. 1539; straight bracket, overall dim. 1-31/32" long x 7/16" wide, mounting bracket slot 3/4" long x 3/16" wide.	Dial light socket	Bendix	A104910
274	2C4439A/A2	OSCILLATOR ASSEMBLY: Contains Ref. Nos. 204-4, 204-5, 205-10 through -14, 218, 219-1, 219-2, 220, 221, 222, 223, 224, 225, 226, 276-1.		Bendix	N91052-1
275	2C4439A/A1	R.F. ASSEMBLY (including mixer and 1st I.F.): 2 mounting holes 1-13/16" center to center to clear No. 6-32 screws; contains Ref. Nos. 201, 202A, 202B, 202C, 203, 204-1, 204-2, 204-3, 205-1 through -9, 206, 207, 208, 209, 210, 211-1, 211-2, 212, 213, 214, 215-1, 216, 217.		Bendix	N91050-1

Revised 14 August 1944

AN 08-403C639-2

276-1	3DA1-58	CAPACITOR: Fixed; mica; 1000 mmfd. \pm 20%, 500 volt test; No. 20 AWG leads 1-1/4" long, 11/16" long x 7/16" wide x 13/64" deep; Aerovox 1468ST or LST, Cornell-Dubilier 5WST, Micamold Type O, Sangamo Type K, Solar Type MOFW or MDCW. (Note B).	Osc. grid coupling	C.D., Aerovox Micamold, Sangamo, Solar	C58469-102
276-2	3DA1-58	Same as 276-1. (Note B).	CW osc. grid coupling	C.D., Aerovox Micamold, Sangamo, Solar	C58469-102
276-3	3DA1-58	Same as 276-1.	B + input filter	C.D., Aerovox Micamold, Sangamo, Solar	C58469-102
276-4	3DA1-58	Same as 276-1.	Heater input r-f filter	C.D., Aerovox Micamold, Sangamo, Solar	C58469-102
278-1	3RC30BE331K or 3ZK6033-19	RESISTOR: Fixed; carbon; 330 ohms \pm 10%, 1 watt; JAN Type No. RC30BE331K	To balance impedance of line to Loudspeaker	JAN	
278-2		Same as 278-1			
VT-103	2J6SQ7	TUBE: JAN-6SQ7.	Det. 1st audio, a-v-c	Ken-rad, R.C.A.	
VT-152	2J6K6GT	TUBE: JAN-6K6GT.	2nd audio	Ken-Rad, R.C.A.	
VT-202	2J9002	TUBE: JAN-9002.	H-f oscillator	Ken-Rad, R.C.A.	
VT-203	2J9003	TUBE: JAN-9003.	R-f amplifier	Ken-Rad, R.C.A.	
VT-203	2J9003	TUBE: JAN-9003.	Mixer	Ken-Rad, R.C.A.	
VT-203	2J9003	TUBE: JAN-9003.	Doubler	Ken-Rad, R.C.A.	
VT-211	2J6SG7	TUBE: JAN-6SG7.	1st i-f amp.	Ken-Rad, R.C.A.	
VT-211	2J6SG7	TUBE: JAN-6SG7.	2nd i-f amp.	Ken-Rad, R.C.A.	
VT-211	2J6SG7	TUBE: JAN-6SG7.	3rd i-f amp.	Ken-Rad, R.C.A.	
VT-211	2J6SG7	TUBE: JAN-6SG7.	CW oscillator	Ken-Rad, R.C.A.	
	2Z8654.7	SOCKET: Tube; octal; 8 prong with No. 4 retainer ring; 1-1/4" dia. x 7/8" high; with ring 907658 grooved for a 1/32" to 1/16" panel; groove located 0.020" below mounting surface; for Tube VT-103; Amphenol Type S8TM.	Tube Socket	Amph.	A104087
	2Z8654.7	Same as above, for Tube VT-152.	Tube socket	Amph.	A104087

Note A.—Replace entire assembly in which this item is used.

Note B.—Replaceable with difficulty. Replace entire assembly in which item is used whenever possible.

*Any value from 600 to 1,000 mmf. acceptable. See table for alternate preference.

Reference Symbol	Army Stock No. Navy Stock No. British Ref. No.	Name of Part and Description	Function	Mfr. and Desig. or AWS Type	Cont. or Govt. Dwg. or Spec. No.
	2Z8654.7	Same as above, for Tube VT-211.	Tube socket	Amph.	A104087
	2Z8654.7	Same as above, for Tube VT-211.	Tube socket	Amph.	A104087
	2Z8654.7	Same as above, for Tube VT-211.	Tube socket	Amph.	A104087
	2Z8654.7	Same as above, for Tube VT-211.	Tube socket	Amph.	A104087
	2Z8657-3	SOCKET: Tube; octal; with ring; No. 2-9, 7 pin, 11/16" lip, 5/8" hole, 3/8" deep, 7/8" diam. retaining ring, for Tube VT-202, Amphenol Type 78-7 PT. (Note A).	Tube socket	Amph.	A102980
	2Z8657-3	Same as above, for Tube VT-203. (Note A).	Tube socket	Amph.	A102980
	2Z8657-3	Same as above, for Tube VT-203. (Note A).	Tube socket	Amph.	A102980
	2Z8657-3	Same as above, for Tube VT-203. (Note A).	Tube socket	Amph.	A102980
	2Z9402.81	TERMINAL BOARD ASSEMBLY: Capacitor and resistor; phenolic; 1/16" thick x 2" wide x 4" long; includes Ref. Nos. 230-17, 236-4 and 5, 247, 248, 249, 250.	Terminal board	Bendix	A104850
	2Z9402.78	TERMINAL BOARD ASSEMBLY: Resistor and capacitor; phenolic; 1/8" thick x 1/4" wide x 3 3/8" long; mounting holes centered in each end and centered 1/4" from edge; two other holes 5/8" and 25/32" respectively from left end; two holes 3/16" from each side and spaced 19/32" and 1-3/32" respectively from right end; includes Ref. Nos. 255, 257, 261.	Terminal board	Bendix	A105008
	2Z9402.77	TERMINAL BOARD ASSEMBLY: Resistor and capacitor; phenolic; 1/8" thick x 1 3/8" wide x 3 1/4" long; five mounting holes 5/32" from side and spaced beginning 3/8" from left side, 3/8", 1 1/8", 1-13/16", 2-13/32" and 2-13/32"; two mounting holes centered in each end and 3/16" in from edge; complete with resistors and capacitors mounted; includes Ref. Nos. 230-19, 264, 265, 267, 268.	Terminal board	Bendix	A106052
	2Z9409.14	TERMINAL STRIP AND LUG ASSEMBLY: Phenolic; 1/8" thick x 3/8" wide x 4-21/32" long; two mounting holes and six terminal pins.	Terminal board in R-f assembly	Bendix	A104914-1
	2Z9402.79	TERMINAL BOARD ASSEMBLY: Phenolic; 1/8" thick x 3/8" wide x 3-3/32" long; four soldering pins and two spacers 5/16" dia. x 3/8" long.	Terminal board in H.F. osc. assembly	Bendix	A105058-1

Revised 14 August 1944

AN 08-408C639-2

2Z9416.17	TERMINAL BOARD ASSEMBLY: Phenolic; 1/8" thick x 7/16" wide x 12 1/8" long; four mounting holes, fifteen lug terminals.	Terminal board	Bendix	A105005
2C5539A/D1	DIAL: Calibrated 99 to 158 mc.; 4.00" dia., .75" dia. hole for shaft; 4 mounting holes 1" center to center; 90° rotation.	Tuning indicator	Bendix	C58586
2Z5927	LAMP: LM-27; Bayonet; 6-8 volt, 1/4 amp.; GE Mazda, Type 44; Bulb T-3-1/4 Model ATU-26.	Illuminate dial	G.E.	A9320-1
2Z2643.2	CLAMP: Tube; used with 1/4" tube base; mounting slot .144" x .206", 57/64" apart; interchangeable with Birtcher Corp. No. 926-B.	Tube clamp	Westinghouse	A105391
2C4439A/F1	SHIELD: Contact; antenna socket fitting; 1-19/32" dia. x .085" flange, 29/32" long overall; 3 No. 6-32 holes at 60°, 180° and 240° on flange 1.343" dia.; 3 No. 40 countersunk holes at 120°, 240°, 0° on .875" dia. center holes .532" Hub 19/32" O.D.	Antenna socket fitting	Bendix	A105912
2Z3290.3	COUPLING: Flexible; insulated brass ring in center fastened by flat springs to (2) stainless steel hubs; each drilled for 3/8" dia. shaft; each hub has (2) holes tap No. 6-32 on 90° spacing cadmium plated 1 1/2" dia. x 11/16" length.	Shaft coupling	Bendix	A104862-1
6R57400-6	WRENCH: Hex; L-shaped; 1/16", .0615" across flats; fits No. 5, 0.125" and No. 6 Allen socket head set screw; No. 27397.	Wrench	Allen	A18190-6
2Z5854	POINTER AND KNOB ASSEMBLY: Black phenolic; 1 1/8" dia. x 5/8" thick; (2) set screws 135° and 225° clockwise from pointer for .25" diam. shaft (2) No. 8-32 set screws.	ON TONE CONTROL	K-K	A104855-1
2Z5854	Same as above.	ATTENUATION control	K-K	A104855-1
2Z5854	Same as above.	R-F GAIN INCREASE CONTROL	K-K	A104855-1
2Z5854	Same as above.	AUDIO GAIN INCREASE CONTROL	K-K	A104855-1
2Z5854	Same as above.	CW AND MANUAL-MANUAL A-V-C control	K-K	A104855-1

Note A.—Replace entire assembly in which this item is used.

Note B.—Replaceable with difficulty. Replace entire assembly in which item is used whenever possible.

*Any value from 600 to 1,000 mmf. acceptable. See table for alternate preference.

MODEL: RADIO RECEIVER BC-639-A

Reference Symbol	Army Stock No. Navy Stock No. British Ref. No.	Name of Part and Description	Function	Mfr. and Desig. or AWS Type	Cont. or Govt. Dwg. or Spec. No.
	2Z5786.7	KNOB ASSEMBLY: Cast with friction clutch; includes knob brass casting painted black; 2 1/2" dia. x 23/32" deep; 2 holes for set screws; stainless steel hub type 303 with 0.251" diameter holes; No. 6-32 tap holes at 0° and 90° counter-clockwise; O.D. 0.744" shank 0.623" O.D. x .724" long; 3/8"-32 thread on end for 5/32".	Tuning control	Bendix	A104891-1
	2Z4880-13	DIAL WINDOW: Transparent window with vertical hair line; 3-3/16" long x 1-7/16" wide x 0.060" thick; 2 No. 40 DR. .098" holes spaced 2.187" center to center and 1-7/32" from straight edge; white line 1 1/4" from one end; 2 half circles each 2 1/32" from white line, cut on 3/16" radius one end chamfered to 45° "vinylite".	Identification	Bendix	A104906
	2Z3717.8	DIAL AND HUB: Frequency indicator; tuning; dial face 4" dia., .020" thick; (4) No. 40 holes 45° apart on 1" dia.; center reamed .750" periphery marked 100-155 for 270° align and stop; hub 3/4" dia. x .343" long; brass spiral groove; 1 turn collar 1 1/4" dia. x .038" thick; (4) No. 40 DR. 45° apart on .749" dia.; (2) set screws No. 6-32 fastener 3-3/16" long x .01" dia.; ring loop on end .063" dia. Loop twist other end .031" dia. x 1/8" long; steel or nickel plated music wire.	Tuning	Bendix	A102604-1
	6D7400T639A	Instruction Book for Operation and Maintenance of Radio Receiver BC-639-A. Technical Order 8 1/2" x 11".	Instruction	Bendix	
	2Z7242-25/1	SHIELD: Contact. (Part of Ref. No. 200).	Shield	Bendix	A102615

Note A.—Replace entire assembly in which this item is used.

Note B.—Replaceable with difficulty. Replace entire assembly in which item is used whenever possible.

*Any value from 600 to 1,000 mmf. acceptable. See table for alternate preference.

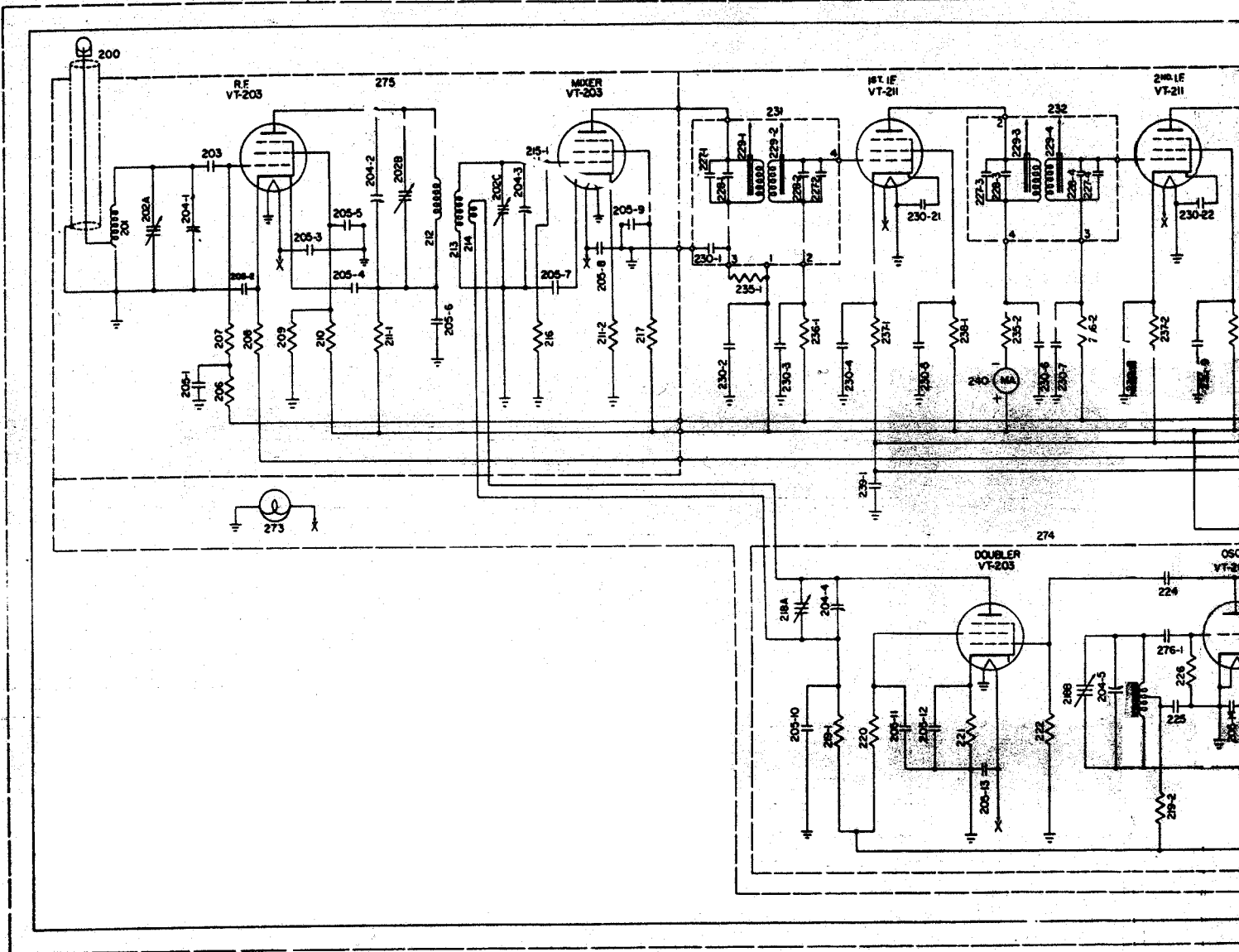

REF NO.	DESCRIPTION	DWG NO.	REF. NO.	DESCRIPTION	DWG NO.	REF. NO.	DESCRIPTION
200	ANTENNA PLUG	C58585	205-8	680MMF, 500V DCW CAP. •	C58469-102	211-1	1,000 OHMS, 1/2 W RES.
201	ANTENNA COIL	A105064	205-9	680MMF, 500V DCW CAP. •	C58469-102	211-2	1,000 OHMS, 1/2 W RES.
202	GANG CAP (3 SEC)	L72799-2	205-10	680MMF, 500V DCW CAP. •	C58469-102	212	R.F. PLATE COIL
203	15MMF, 500V DCW CAP.	C58469-150	205-11	680MMF, 500V DCW CAP. •	C58469-102	213	MIXER GRID COIL
204-1	TRIMMER CAP.	L72799-2	205-12	680MMF, 500V DCW CAP. •	C58469-102	214	DOUBLER PLATE
204-2	TRIMMER CAP.	L72799-2	205-13	680MMF, 500V DCW CAP. •	C58469-102	215-1	47MMF, 500V DCW
204-3	TRIMMER CAP.	L72799-2	205-14	680MMF, 500V DCW CAP. •	C58469-102	215-2	47MMF, 500V DCW
204-4	TRIMMER CAP.	L72799-2	205-15	680MMF, 500V DCW CAP. •	C58469-102	216	1.8 MEGOHMS 1/2 W R
204-5	TRIMMER CAP.	L72799-2	205-16	680MMF, 500V DCW CAP. •	C58469-102	217	270,000 OHMS 1/2 W R
205-1	680MMF, 500V DCW CAP. •	C58469-102	205-17	680MMF, 500V DCW CAP. •	C58469-102	218	GANG CAP. (2 SEC)
205-2	680MMF, 500V DCW CAP. •	C58469-102	205-18	680MMF, 500V DCW CAP. •	C58469-102	219-1	4,700 OHMS 1/2 W RES.
205-3	680MMF, 500V DCW CAP. •	C58469-102	206	100,000 OHMS, 1/2 W RES.	A102978-104	219-2	4,700 OHMS 1/2 W RES.
205-4	680MMF, 500V DCW CAP. •	C58469-102	207	560,000 OHMS, 1/2 W RES.	A102978-564	220	56,000 OHMS 1/2 W RES.
205-5	680MMF, 500V DCW CAP. •	C58469-102	208	330 OHMS, 1/2 W RES.	A102978-331	221	560 OHMS 1/2 W RES.
205-6	680MMF, 500V DCW CAP. •	C58469-102	209	120,000 OHMS, 1/2 W RES.	A102978-124	222	27,000 OHMS 1/2 W RES.
205-7	680MMF, 500V DCW CAP. •	C58469-102	210	39,000 OHMS, 1/2 W RES.	A18004-393	223	H.F. OSC. COIL

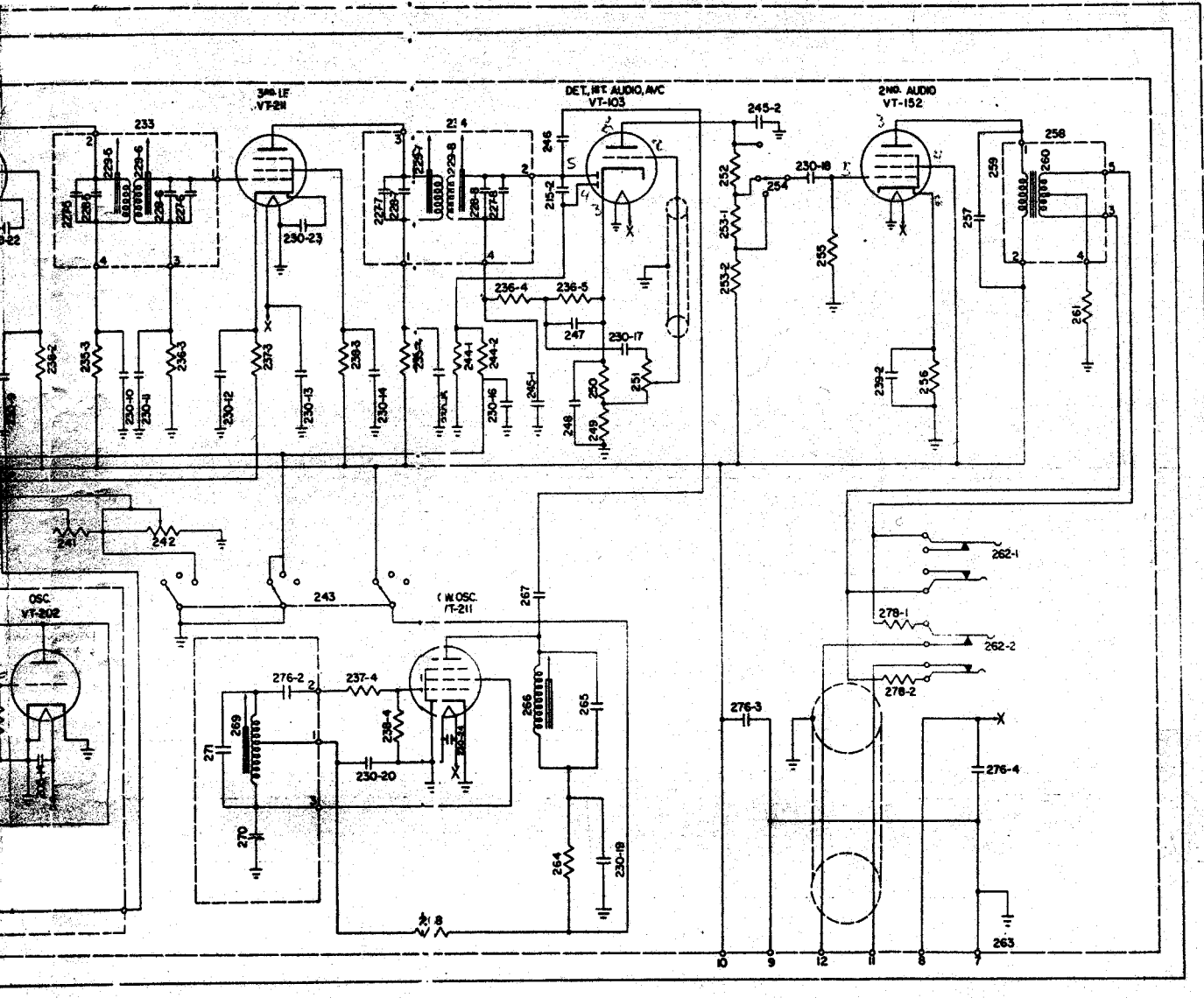

DWG. NO.	REF. NO.	DESCRIPTION	DWG. NO.	REF. NO.	DESCRIPTION	DWG. NO.
A102975-102	224	27M MF, 500V DCW CAP.	C58469-270	228-6	60MMF, 500V DCW CAP.	C58495-600
A102975-102	225	150MMF, 500V DCW CAP.	C58469-181	228-7	60MMF, 500V DCW CAP.	C58495-600
A105065	226	47,000 OHMS 1/2W RES.	A102975-473	228-8	60MMF, 500V DCW CAP.	C58495-600
A105066	227-1	15M MF, 500V DCW CAP.	A25715-15	229-1	IF COIL	AA104206-1
A104311	227-2	15M MF, 500V DCW CAP.	A25715-15	229-2	IF COIL	AA104206-1
C58469-470	227-3	15M MF, 500V DCW CAP.	A25715-15	229-3	IF COIL	AA104206-1
C58469-470	227-4	15M MF, 500V DCW CAP.	A25715-15	229-4	IF COIL	AA104206-1
A102975-185	227-5	15M MF, 500V DCW CAP.	A25715-15	229-5	IF COIL	AA104206-1
A102975-274	227-6	15M MF, 500V DCW CAP.	A25715-15	229-6	IF COIL	AA104206-1
L72798-2	227-7	15M MF, 500V DCW CAP.	A25715-15	229-7	IF COIL	AA104206-1
A102975-472	227-8	15M MF, 500V DCW CAP.	A25715-15	229-8	IF COIL	AA104206-1
A102975-472	228-1	60M MF, 500V DCW CAP.	C58495-600	230-1	.0068MFD, 500V DCW CAP.	A102967-8
A102975-563	228-2	60M MF, 500V DCW CAP.	C58495-600	230-2	.0068MFD, 500V DCW CAP.	A102967-8
A102975-561	228-3	60M MF, 500V DCW CAP.	C58495-600	230-3	.0068MFD, 500V DCW CAP.	A102967-8
A102975-273	228-4	60M MF, 500V DCW CAP.	C58495-600	230-4	.0068MFD, 500V DCW CAP.	A102967-8
A105061	228-5	60M MF, 500V DCW CAP.	C58495-600	230-5	.0068MFD, 500V DCW CAP.	A102967-8

Revised 1 April 1956

REF. NO.	DESCRIPTION	DWG. NO.	REF. NO.	DESCRIPTION	DWG. NO.
230-6	.0068MFD, 500V DCW CAP. **	A102967-8	247	220 MMF, 500V DCW CAP.	C58469-221
230-7	.0068MFD, 500V DCW CAP. **	A102967-8	248	0.1 MFD, 400V DCW CAP.	A18011-104
230-8	.0068MFD, 500V DCW CAP. **	A102967-8	249	18,000 OHMS, 1/2 W RES.	A18001-183
230-9	.0068MFD, 500V DCW CAP. **	A102967-8	250	2,200 OHMS, 1/2 W RES.	A18001-222
230-10	.0068MFD, 500V DCW CAP. **	A102967-8	251	1 MEG, VOLUME CONTROL	A102616
230-11	.0068MFD, 500V DCW CAP. **	A102967-8	252	68,000 OHMS, 1/2 W RES.	A102975-683
230-12	.0068MFD, 500V DCW CAP. **	A102967-8	253-1	33,000 OHMS, 1/2 W RES.	A102975-333
230-13	.0068MFD, 500V DCW CAP. **	A102967-8	253-2	33,000 OHMS, 1/2 W RES.	A102975-333
230-14	.0068MFD, 500V DCW CAP. **	A102967-8	254	ATTENUATOR SWITCH	C58584
230-15	.0068MFD, 500V DCW CAP. **	A102967-8	255	330,000 OHMS, 1/2 W RES.	A102975-334
230-16	.0068MFD, 500V DCW CAP. **	A102967-8	256	560 OHMS, 2W RES.	RC41BE561J
230-17	.0068MFD, 500V DCW CAP. **	A102967-8	257	.0068 MFD, 500V DCW CAP.	A25714-7
230-18	.0068MFD, 500V DCW CAP. **	A102967-8	258	OUTPUT TRANS.	A103058
230-19	.0068MFD, 500V DCW CAP. **	A102967-8	259	PRI. OUTPUT TRANS.	A103058
230-20	.0068MFD, 500V DCW CAP. **	A102967-8	260	SEC. OUTPUT TRANS.	A103058
230-21	.0068MFD, 500V DCW CAP. **	A102967-8	261	4700 OHMS, 1/2 W RES.	A18001-472
230-22	.0068MFD, 500V DCW CAP. **	A102967-8	262-1	PHONE JACK	A103533
230-23	.0068MFD, 500V DCW CAP. **	A102967-8	262-2	PHONE JACK	A103533
231	1ST I.F. ASSEM.	AL73530-1	263	JONES PLUG	A105106
232	2ND I.F. ASSEM.	AL73531-1	264	4700 OHMS, 1/2 W RES.	A18004-472
233	3RD I.F. ASSEM.	AL73026-4	265	100 MMF, 500V DCW CAP.	C56317-101
234	4TH I.F. ASSEM.	AL73028-2	266	C.W. OSC. PLATE COIL	AA106068
235-1	1,000 OHMS, 1/2 W RES.	A18001-102	267	4.7 MMF, 500V DCW CAP.	C58469-47
235-2	1,000 OHMS, 1/2 W RES.	A18001-102	268	47,000 OHMS, 1/2 W RES.	A18004-473
235-3	1,000 OHMS, 1/2 W RES.	A18001-102	269	C.W. OSC. GRID COIL	A105036-1
235-4	1,000 OHMS, 1/2 W RES.	A18001-102	270	VARIABLE CAP.	A105041
236-1	100,000 OHMS, 1/2 W RES.	A18001-104	271	390 MMF, 500V DCW CAP.	C56317-391
236-2	100,000 OHMS, 1/2 W RES.	A18001-104	272	C.W. OSC. COIL ASSEM.	C58590-1
236-3	100,000 OHMS, 1/2 W RES.	A18001-104	273	DIAL LIGHT ASSEM.	A104910
236-4	100,000 OHMS, 1/2 W RES.	A18001-104	274	H.F. OSC. ASSEMBLY	AN91052-1
236-5	100,000 OHMS, 1/2 W RES.	A18001-104	275	R.F. ASSEMBLY	AN91050-1
237-1	220 OHMS, 1/2 W RES.	A18001-221	276-1	.001MFD, 500V DCW CAP.	C58469-102
237-2	220 OHMS, 1/2 W RES.	A18001-221	276-2	.001MFD, 500V DCW CAP.	C58469-102
237-3	220 OHMS, 1/2 W RES.	A18001-221	276-3	.001MFD, 500V DCW CAP.	C58469-102
237-4	220 OHMS, 1/2 W RES.	A18001-221	276-4	.001MFD, 500V DCW CAP.	C58469-102
238-1	47,000 OHMS, 1/2 W RES.	A18001-473	278-1	330 OHMS, 1W RES.	RC30BE331K
238-2	47,000 OHMS, 1/2 W RES.	A18001-473	278-2	330 OHMS, 1W RES.	RC30BE331K
238-3	47,000 OHMS, 1/2 W RES.	A18001-473			
238-4	47,000 OHMS, 1/2 W RES.	A18001-473			
239-1	1.0 MFD, 100V DCW CAP.	A104484	VT-103	DET., 1ST AUDIO, AVC	
239-2	1.0 MFD, 100V DCW CAP.	A104484	VT-152	2ND AUDIO	
240	0-10 MILLAMMETER	A104194-4	VT-202	H.F. OSC.	
241	300 OHMS, THES. CONTROL	A105022	VT-203	R.F. AMPLIFIER	
242	3000 OHMS, GAIN CONTROL	C58961	VT-203	MIXER	
243	SELECTOR SWITCH	C58583	VT-203	DOUBLER	
244-1	1 MEGOHM, 1/2 W RES.	A102975-105	VT-211	1ST I.F.	
244-2	1 MEGOHM, 1/2 W RES.	A102975-105	VT-211	2ND I.F.	
245-1	330 MMF, 500V DCW CAP.	C58469-331	VT-211	3RD I.F.	
245-2	330 MMF, 500V DCW CAP.	C58469-331	VT-211	C.W. OSC.	
246	1.8 MMF, 500V DCW CAP.	C56336-18			

* ANY VALUE FROM
1000 MMF TO 600 MMF.
IS ACCEPTABLE.

** ANY VALUE FROM
.01MFD TO .006 MFD
IS ACCEPTABLE.

Figure 22 - Radio Receiver BC-639-A, Schematic Diagram